



EN

DEHUMIDIFIER

PLATINUM EVO 21
PLATINUM EVO 41



SERVICE MANUAL

Read the instructions carefully before operating or servicing the dehumidifier.
Observe all the safety instructions; failure to observe the instructions may lead to accidents and/or damage.
Keep these instructions in a safe place for future reference.

Table of Contents

Part I : Technical Information	1
1.Summary	1
2.Specifications	2
3.Outline Dimension Diagram	4
4.Refrigerant System Diagram	5
5.Electrical Part	6
5.1 Wiring Diagram.....	6
5.2 PCB Printed Diagram.....	8
6.Function and Control	10
Part II : Maintenance	14
7.Notes Maintenance	14
8.Maintenance	20
9.Exploded View and Parts List	25
10.Removal Procedure	29
Appendix:	52
Appendix 1: Reference Sheet of Celsius and Fahrenheit.....	52
Appendix 2: Resistance Table of Tube Temperature Sensor	53

Abbreviations Used Within this manual:

Abbreviation	Clear Words
OFDN	Oxygen free and dry nitrogen
PPE	Personnel protective equipment
LFL	Lower flammability level
UFL	Upper flammability level
HC	Hydrocarbon

INTRODUCTION

ATTENTION



Please read this manual carefully before installing and operating Hydrocarbon Air- Conditioner unit.

Careless installation and operation could cause severe injuries to operators, workers and damage to the air-conditioner unit itself.

Keep this manual in a location for easy access as it is needed for reference during installation, maintenance, service and operation of the unit.

This manual does not cover all aspects of installation, maintenance and service of the chiller units; if additional information is needed, contact the GREE Customer Service or Sales Office.

General Information

Warning and cautions appear at appropriate locations throughout this manual book.

Notices

General Safety Instructions

Please pay careful attention to these safety instructions, to avoid risks to people and property. Before starting work on maintenance read this manual thoroughly and pay particular attention to the relevant chapters.

Regardless of further requirements of the country, in which the equipment will be installed: assembly, first start up, technical service, maintenance and repair and as well as dismantling and disposal have to be carried out by authorised personnel only.

During every operation strictly follow the instructions within this manual. Pay attention to the specific rules of air conditioning, electrics and refrigerant handling of the country within which the equipment is installed.

Key sections and/or sentences are highlighted with specific icons and symbols to the right side of the page. Please pay particular attention to this information.

The Symbols Used in this manual are as Follows

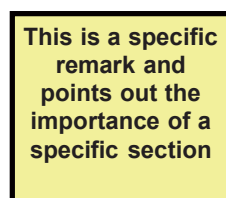

Information window highlighting important content of the specific section or additional information to consider.



This sign will indicate that you are handling a flammable substance and the surrounding environment can possibly contain it.



This is a general warning sign.



The Label is used to indicate that the flammable refrigerant is present within the application and service equipment.

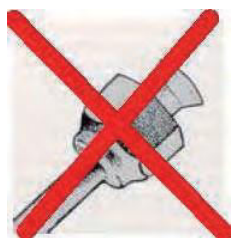

Images that indicate something what you should strictly avoid.



Specific bans!



Specific commandments!



Instructions for first aid!



Fire protection!



Carefully read the instructions!

Working on components with safety-relevant functions jeopardise the safe operation of the installation. In case it is necessary to replace components, only use approved parts. The system contains the refrigerant R-290 (propane). This condition requires special safety precautions to be observed. While working on the system, the presence of any kind of ignition sources (e.g. sparks, open flames, hot surfaces, static electricity) are strictly prohibited. At the installation site, no matter what kind of activities are executed, smoking is strictly prohibited! Likewise, ensure the installation site is well ventilated. For further details as far as it concerns the handling of the refrigerant R-290 (propane) .

Do not charge the system with any refrigerant which is not R-290! Do not mix any refrigerants! Before filling the system, ensure that there is no air (or other non-condensable gases such as nitrogen) left in the system, otherwise there is severe danger of damage to the system caused by excessive high pressure.

After charging the system with refrigerant, carefully examine and confirm the tightness by the use of an appropriate electronic leak detector!

ONLY original spare-parts are permitted for Service and Repair!



Proceed according to the manuals Instructions!



Pay attention to the room size for indoor unit installation!

For specific information refer page XXX of this manual.

The Symbols Used in this manual are as Follows

Electric operations (installation, repair, modification, maintenance, adjustment) have to be fulfilled by trained and authorised personnel only. When dealing with electrical issues, the specific rules of the country within which the equipment is installed must be followed, in addition to the instructions within this manual.

When working on the equipment or parts of it, the system has to be deenergised (by master switch, circuit breaker or separate cut-out) and made safe against restart of the system. Do not reconnect the system to the electric circuit until all work is done and all connections are tested. If handled unsafely or unprofessionally, severe electric shocks can occur. Consider the wiring diagram and follow the instructions of this manual very carefully whilst working on electrical parts. Wrong connections or incorrect grounding may lead to severe injuries and mortal danger.

Ground the system according to the particular requirements of the country within which the equipment is installed.

Connect all the wires properly and durably. Loose cables may lead to overheating or fire

minimum Room Size

HC R290 is a flammable refrigerant and can form explosive mixtures in low concentrations. To minimise the risk of fire or explosion, the system must be installed in a room with a minimum floor area.

minimum Room Size

Unless there are further requirements, standards and legislation of the country within which the equipment is installed may apply. Any technicians that works on GREE hydrocarbon air- conditioners must be competent in the safe handling of flammable refrigerants, in addition to being in possession of knowledge and skills to maintain best refrigeration installation and servicing practices.

There are already training activities in place for engineers, technicians and sales staff to provide professional knowledge and skills for the handling of HC refrigerants and refrigeration systems operating with HCs.

Get your Best Practices knowledge and skills update for HC refrigerants and be certificated for these jobs!



Get trained and have your “HC Refrigeration Professional” certification!



Basics in RAC

Knowledge of the basic SI standard units for temperature, pressure, mass, density, energy.

Understanding of the basic theory of refrigeration systems including the functions of the main components in the system (compressor, evaporator, condenser, thermostatic expansion valves).

Understanding how to read a refrigerant flow chart and an electrical circuit diagram.

The determination of non condensable gases in the refrigeration system and how to eliminate them.

The importance of the use of oxygen free dry nitrogen (OFDN) for system flushing, leak test and strength test.

The elimination of humidity from the refrigeration system and how to recover or vent HC refrigerant from a system.

Usage of tables and diagrams (log p/h diagram, saturation tables of a refrigerant, diagram of a single compression refrigeration cycle) and interpretation of these tables and diagrams.

Knowledge of the basic operation of the following components in a refrigeration system and their role and importance for refrigerant leakage prevention and identification:

- Temperature and pressure controls
- Sight glass and moisture indicators
- Defrost controls, reverse cycle operation
- System protectors
- measuring devices such as the pressure gauge manifold
- Thermometer
- Leak detector
- Refrigerant charging devices
- Vacuum pump
- Oxygen free dry nitrogen cylinder and pressure regulator

Fault finding – analysis and repair.

- Knowledge of flammable refrigerants
- Risk analysis for the application of flammable refrigerant and properties of flammable refrigerants
- Electrical circuit assessment and repair

Read more!
SAFETY CODE
OF PRACTICE
FOR REFRIGE-
RATING SYS-
TEMS
UTILISING A2 &
A3 REFRIGE-
RANTS

ISBN
1 872719 15 5

Checks before putting in operation, after a long period of nonuse, after maintenance or repair intervention or during operation.

Carry out a pressure and leak test to check the strength and the tightness of the system.

Usage of a vacuum pump.

Evacuation of the system to remove air and moisture according to standard practice.



Checks for Leakage

Knowledge of potential leakage points of refrigeration, air-conditioning and heat pump equipment. making a visual and manual inspection of the whole system.

Carry out a check for leakage of the system using an indirect method and/or one of the direct methods.

Direct leak detection methods:

1. Fixed leakage detection systems
2. Portable electronic gas detectors
3. Ultraviolet (UV) indication fluids
4. Weak soapy water solution (bubble test) also in combination with OFDN
5. New installation tightness test for leakage detection procedure e.g. H2/N2
6. Operational system tightness test for leakage detection procedure

Indirect refrigerant detection methods:

1. Visual
2. manual checks

Use of portable measuring devices such as pressure gauges, thermometers and multi-meters for measuring Volt/Amp/Ohm in the context of indirect methods for leakage checking and interpretation of the measured parameters. It is very important to make use of an electronic gas detection device. Take care that the electronic gas detector is designed and certificated for the use with flammable refrigerants. Additionally, the electronic HC gas detector must be part of the Personnel Protective Equipment (PPE) of the technician because if this device is operational in the work area it will warn by detection and signalling if HC refrigerant is in the atmosphere.

The use of OFDN is important and the HC gas detector is indeed a personnel protection device (PPE)!

Handling of the refrigerant during installation, maintenance, servicing or recovery or venting

Usage of scales to weigh refrigerant. Knowledge of requirements and procedures for handling, storage and transportation especially of flammable refrigerants and especially of contaminated refrigerant and of oils. Safe HC refrigerant recovery and venting.

Installation, commissioning and maintenance of a compressor

The basic functioning of a compressor (including capacity control and lubricating system) and risks of refrigerant leakage to its operation. Installing a compressor properly, including control and safety equipment. Adjusting the safety and control switches. Checking the oil return system. Start up and shut down a compressor and checking the good working conditions of the compressor, including by making measurements during operation of compressor.

Installation, commissioning and maintenance of condensers

The basic functioning of a condenser. Installing a condenser properly, including control and safety equipment. Adjusting the safety and control switches. Checking the hot-gas and liquid lines in correct positions. Start up and shut down a condenser and check the good working conditions, including by making measurements during operation. Checking the surface of the condenser. Methods for condenser surface cleaning and fins adjustments.



Installation, commissioning and maintenance of evaporators

The basic functioning of an evaporator (including defrosting system). Installation of an evaporator including control and safety equipment. Adjusting the safety and control switches. Checking the liquid and suction pipelines in the correct position and checking the hot gas defrost pipeline. Start up and shut down an evaporator and check the good working of the evaporator, including by making measurements during operation. Functional checking of the reverse cycling control device. Checking the surface of the evaporator. Methods for evaporator surface cleaning and fins adjustments.

Preventive maintenance will improve the system efficiency

Piping

Professional brazing is another key component for safe and state of the art HC system installation and servicing. Brazing leak free joints on metallic tubes and pipes that can be used in refrigeration, air-conditioning or heat pump systems. make/check pipe and component supports and vibration elimination. Knowledge about the designing and dimensioning of the different refrigeration system section pipes including risers. The behaviour of lubricants within the refrigeration system and the influences of the dimensioning of pipe work in relation to lubricants. Develop strategies to minimise mechanical connections like fl or fl and to provide a sealed (hermetic) system.

Regular professional brazing experience is an important precondition for the work with hydrocarbon refrigerants!

HC R290 Refrigerant Issues

Please notice that the unit is filled with propane. Details to this refrigerant are found in chapter "refrigerant". Propane is highly flammable and leads to explosion under certain conditions. Inappropriate treatment of the unit involves the risk of severe damages of people and material.

Basics

HC R-290 (propane) is an odourless and colourless gas of the group of hydrocarbons.

HC R-290 is heavier than air and at high concentrations can cause narcotic effects and eventually asphyxiation.

R-290 is highly flammable within the range of 2,1% and 9,5% by volume, or 38 g/m³ to 170 g/m³ in air. The auto-ignition temperature is about 470°C.

Since R-290 is an odourless and colourless gas, it is difficult to perceive that it is present (as with most other refrigerants).

Propane is often used as a fuel such as for heating or barbecues. However, for use on refrigeration systems, fuel-grade propane is not suitable since it contains high levels of impurities, which would damage the refrigeration system and may not provide the desired refrigerating capacity or efficiency.



HC R-290 refrigerant has a high grade of purity.

Propane as a cooking gas is not useful for refrigeration purpose!

The structural formula of HC R-290 (propane)

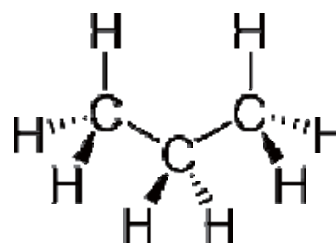

Important Refrigerant Properties and Parameters:

molecular formula	C3H8
melting point [°C]	-188
Boiling point under atmospheric pressure [°C]	-42
molar mass [g mol ⁻¹]	44,10
Critical temperature [°C]	96,8
Critical pressure [bar]	42
Practical limit [g/m ³]	8
Lower flammability level LFL [g/m ³]	38
Lower flammability level LFL [%]	2,1
Upper flammability level UFL [g/m ³]	171
Upper flammability level UFL [%]	9,5
Ignition temperature [°C]	470

Read More!

Guidelines for the safe use of hydrocarbon refrigerants

GIZ—PROKLIMA

<http://www.gtz.de/proklima>

Flammability

Three components are needed simultaneously for causing fire:

1. Oxygen
2. Ignition source and
3. The flammable concentration of HC

For ignition, the concentration of HC in air has to be between the lower and upper flammable limits. If the concentration is below the lower flammability limit (LFL) of about 2% by volume in air, there is not enough HC for combustion. If the concentration is above the upper flammability limit (UFL) of about 10% there is insufficient oxygen for combustion.

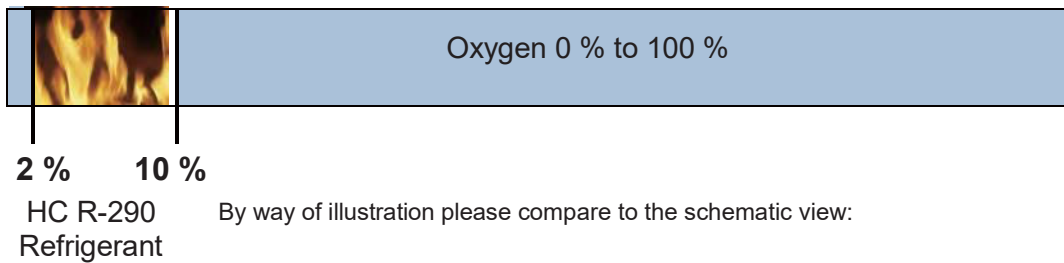

Possible ignition sources are:

1. A flame, for example from brazing torch, halide torch, leak lamp, match or lighter, cigarette
2. A spark from an electrical component
3. Static electricity
4. Hot surfaces



To ignite HC R-290, three (3) components must exist at the same time at work area to cause the refrigerant burning!



Safety Data

Hazard Identification

- Extremely flammable (F+).
- Readily forms an explosive air-vapour mixture at ambient temperatures.
- Vapour is heavier than air and may travel to remote sources of ignition (e.g. along drainage systems, into basements etc).
- Liquid releases generate large volumes of flammable vapour (approx 250:1)
- Cold burns (frostbite) will result from skin / eye contact with liquid.
- Liquid release or vapour pressure jets present a risk of serious damage to the eyes.
- Abuse involving inhalation of high concentrations of vapour, even for short periods, which can produce unconsciousness or may prove fatal. Inhalation may cause irritation to the nose and throat, headache, nausea, vomiting, dizziness and drowsiness. In poorly ventilated areas unconsciousness or asphyxiation may result.

1 kg of liquid HC R-290 refrigerant creates about 250 litres of gas

Beside the flammability, most other safety properties are similar to other refrigerants!

Rely always on best service practices in refrigeration!

First Aid measures

Inhalation:

Remove the affected person to fresh air. If breathing has stopped, administer artificial respiration. Give external cardiac massage if necessary. If the person is breathing but unconscious, place them in the recovery position. Obtain medical assistance immediately.

Skin:

In case of cold burns: flush with water to normalize temperature. Cover the burns with sterile dressings. Do not use ointments or powders. Obtain medical assistance immediately.

Eyes:

Cold burns should be flushed with water to normalise temperature, cover the eye with a sterile dressing and obtain medical assistance immediately.

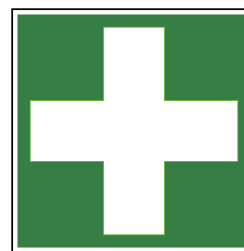

Fire Fighting measures

HC R-290 is delivered, stored, and used at temperatures above their flash point. Avoid all naked flames, sparks, cigarettes etc.

- In case of fire, immediately alert fire brigade
- Ensure an escape path is always available from any fire
- If gas has ignited do not attempt to extinguish but stop gas flow and allow to burn out.
- Use water spray to cool heat-exposed containers, and to protect surrounding areas and personnel effecting the shut off
- Every precaution must be taken to keep containers cool to avoid the possibility of a boiling liquid expanding vapour explosion (BLEVE)

Extinguishing media:

In case of a large fire:

Release must be stopped and container cooled by water spray.

Water mist should be used to assist approach to the source of the fire.

Large fires should only be handled by Fire Brigade.

DO NOT USE WATER JET

Small fire:

Use dry powder extinguisher



DO NOT USE WATER JET



Special protective equipment for fire fighters:

In confined spaces use self-contained breathing apparatus

Hazardous combustion products:

Incomplete combustion may form carbon monoxide.

Accidental Release measures

Immediate emergency action:

- Clear people away from the area to a safe place
- Do not operate electrical equipment unless “Ex”-rated
- Summon the emergency services
- Treat or refer casualties if necessary

Further actions:

- Stop release
- Use dry powder or carbon dioxide extinguishers
- Cool containers exposed to fire by using water / mist spray.

Further action (when release is made safe):

- Extinguish all naked lights – avoid creating sparks
- Position fire fighting equipment
- Cover drains and disperse vapour with water spray.

Note: vapour may collect in confined spaces.

Accidental Release measures

Due to the flammability of R-290 and the risk of fire or explosion during servicing, special safety rules must be followed during operation. In order to avoid damage for people and property, particular requirements are listed hereafter.

Before servicing the unit, the surrounding area where the work will be done must be clear of safety hazards to ensure safe working. Nevertheless it is required to carry out a risk assessment in order to minimise the risk of ignition of R-290.



The following safety measures must be followed:

1. Any employees and other present persons must be informed about the service and the way the service is done, first.
2. It is recommended to isolate the working environment in order to keep out any unauthorised personnel.
3. It is useful to set up signs such as „no smoking“ or „access denied“.
4. It is prohibited to store any combustible goods within the working environment.
5. Within two (2) metres radius, ignition sources are not allowed in the working area.
6. Fire extinguisher (dry powder) must be easily accessible at any time.
7. During service work, proper ventilation of the environment must be ensured.



The HC leak detector is indeed a Personal Protective Equipment (PPE) device!



Sign plate to protect and mark the working area.

Appropriate detectors, suitable for hydrocarbons, must be available and operational all the time. Appropriate tools and appliances must be available and ready for operation.

Any employees need to be instructed extensively about the safety measures and the possible safety hazard.

Refrigerant Recovery

Before starting service work on the refrigerant circuit, the existing refrigerant must be removed. When carrying out removal of the refrigerant, the following must be considered:

- The recovery cylinder must be permitted for the use of R-290 (especially regarding the pressure and the compatibility of the connectors and the valves).
- The recovery machine must be suitable for operation with R-290. Importantly, the recovery machine must not itself be an ignition source.
- The filling of the recovery cylinder should be monitored closely by controlling the weight. It is recommended to place and then to leave the cylinder on a digital scale. Pay attention to not overfilling the cylinder. The cylinder is only allowed to be filled up to 80% of its complete volume by liquid refrigerant.
- The pressure must be controlled in order to ensure that the permissible pressure of the cylinder is not exceeded at any time.
- After filling, the cylinder must be marked with the mass and the type of refrigerant recovered.
- The recovery machine should be operated until the pressure reduces to 0,3 bar absolute pressure. R-290 is soluble to oil. This may lead to a rise of pressure because the refrigerant vaporises from oil. It may be necessary to operate the recovery machine for a second or even a third time.
- Small amounts of R-290 can be vented in safe manner to the environment.
- Remaining amounts of HC absorbed by the oil can be extracted from the system using a vacuum pump in combination with an exhaust vent hose.
- A second "two way excess" recovery cylinder can be used in serial connection to act as an oil-separator.
- After the systems' pump out, the system should be flushed with oxygenfree dry nitrogen (OFDN) in order to ensure no flammable gas are inside the system.



Repair of Leaks

System leaks must be immediately repaired by authorised personnel after becoming acquainted. If they cannot be repaired immediately, the refrigerant charge should be removed from the system until the point at which the leak can be properly repaired.

- Removing the refrigerant from the system in order to avoid an uncontrolled discharge.
- Examine the leak source, determining the reason for the leak and carry out the proper course of action
- Repair properly (NO „temporary repairing“)
- Based on the results of the systems' examination, suitable measures need to be identified in order to avoid a recurrent appearance of the leak.
- Before embarking on the repair, ensure that the refrigerant has been removed and the system flushed with OFDN, especially if brazing is to take place
- After each intervention into a refrigeration system (repairing leaks, replacing components, brazing) the system must be subject to a leak test and following strength test of the system.



Regular professional brazing experience is an important precondition for the work with hydrocarbon refrigerants!

The use OFDN is an important precondition for professional leak repair!

1. System flushing from HC
2. Inert gas brazing
3. Leak testing
4. Strength testing
5. Cleaning (blowing) agent

Gas Detection

While servicing the unit it is recommended for the whole period of work — before, during and after — to monitor the gas concentration in the air within the work environment. By monitoring the air within the work environment the danger of a possible formation of flammable atmosphere can be detected early.

Doing the monitoring, ensure that the gas detectors are suitable for hydrocarbon detection. Never use open fire or a device with an ignition source for the detection of gas or for leak detection.

The HC leak detector is indeed a PPE device!

Before operation of the gas detector the instruction manual must be read carefully. In case of any questions refer to the detector manufacturer. Furthermore ensure the detector is correctly calibrated. Instructions for calibration can be found in the instruction manual of the detector or upon request from the manufacturer.

A possible re-calibration must be done within an area which is free of refrigerants.

In case of a positive detection by the detector any work must be stopped immediately. Any open flames or ignition sources must be extinguished or removed. In addition to a suitable and approved HC gas detectors, portable gas detectors can be used.

Such a detector can be clipped to clothing or placed on the floor within the working area. It should be switched on for the duration of the work, and set to alarm at 15% of the lower flammability level (LFL), to warn that flammable concentration may be nearby. In this way, technicians can be alerted whenever an inadvertent release of flammable refrigerant occurs, and can immediately act upon the relevant emergency procedures.



Portable HC Gas Detector



Cylinder Handling

R-290 is available in a large variety of different cylinders which are to be distinguished whether they are refillable or not. Most refillable cylinders are equipped with pressure relief valves, often with own special construction of valves in order to distinguish them from the cylinders of different refrigerants.

Often special legal requirements about the handling of flammable refrigerants exist in the different countries. These requirements must be studied and adhered to. Principally the following regulations in dealing with R-290 cylinders apply:

1. Do not remove or destroy official stickers of the cylinder
2. Close the cylinder with a cap any time the cylinder is not used
3. Never expose the cylinder to direct heat
4. Do not repair or modify the cylinder or the cylinders' connections
5. Only use suitable equipment for transportation of the cylinder, even for short distances. Never roll the cylinder across the ground.
6. Take appropriate measures in order to prevent impurities, water or oil from entering the cylinder.
7. Should it be necessary to warm the cylinder, only use warm water or air which temperature must not exceed 40 °C (104 °F). Open flame or radiant heaters are not allowed at any time.



8. Weigh the cylinder and compare it against the tare weight (normally stamped on the cylinder) in order to make sure that it is empty. Pressure control is no secure method to find out if and how much refrigerant there is inside the cylinder.
9. For accurate charging, use a set of reliable scales with appropriate resolution (depending on the size of system charged with refrigerant) and use the smallest size of cylinder available.
10. For recovery of R-290, only use cylinders which are allowed to be filled with R-290.
11. Make sure that safety inspections are still valid (i.e. within date), specifically with regards to safety test certification.
12. For refillable recovery cylinders keep in mind that with recovered amounts of HC refrigerant, oil will always be present specific amounts may remain in the cylinder after emptying.

Charging HC!

Always use the smallest cylinder possible and rely on appropriate accurate and sensitive scales

The storage of R-290 cylinders is controlled by regulations. These regulations take priority over the present guidelines. Typically, such rules imply the following:

1. Cylinders should be stored in a separate area, preferably outside, otherwise in a dry, well ventilated place far away from any ignition source.
2. Admission to storage area must only be given to authorised personnel only. Storage areas must be labelled with “no smoking” and “no naked flames” sign.
3. Storage areas should be at ground level and never in the basement.
4. Access should be easy – exclude any obstacles.
5. Cylinders should be stored and operated only in an upright position.
6. Choose appropriate measures to prevent static charges
7. Please remember that the maximum quantity of stored refrigerant sometimes might be regulated by national regulations.

Read More!

[Guidlines for the safe use of hydro-carbon refrigerants](#)

GIZ—PROKLIMA

<http://www.gtz.de/proklima>

The transport of cylinders is controlled by laws in most countries. These laws must always be regarded first before the mentioned guidelines here. In many cases information about regulations for the transport of cylinders could be given by the dealer of the refrigerant.

Basically the following must be regarded concerning the transport of R290 cylinders:

1. During the transportation of R290 always carry along printed information about the refrigerant. In case of emergency these information must be easy accessible. There are often different demands to the transporters carrying a great quantity of gas. Inform yourself before the scheduled transport.
2. make yourself familiar with the risks of the refrigerant and the emergency measures in case of accident or emergency.
3. Always carry a fire extinguisher during transportation with you. It should be a dry powder fire extinguisher with a capacity at least of 2 kg. Make sure that the driver is experienced in fire extinguisher operation.
4. Cylinders must be transported in an upright position and be tightly secured.
5. make sure of a proper ventilation inside the van even though it might request a change in the vans' body construction.
6. Place the security advise „flammable gas“ upon the rear side of the van.
7. Smoking or open fire is strictly forbidden inside the van.
8. Do not leave cylinders in a locked van without surveillance longer than necessary.



Pressure—Temperature Chart

HC Refrigerant R-290							
Temperature		Absolute pressure			Gauge pressure		
°C	°F	kPa	bar	PSI	kPa(g)	bar(g)	PSI(g)
-40	-40	111,12	1,11	16,12	11,12	0,11	1,61
-39	-38,2	116,00	1,16	16,83	16,00	0,16	2,32
-38	-36,4	121,05	1,21	17,56	21,05	0,21	3,05
-37	-34,6	126,27	1,26	18,31	26,27	0,26	3,81
-36	-32,8	131,66	1,32	19,10	31,66	0,32	4,59
-35	-31	137,23	1,37	19,90	37,23	0,37	5,40
-34	-29,2	142,97	1,43	20,74	42,97	0,43	6,23
-33	-27,4	148,90	1,49	21,60	48,90	0,49	7,09
-32	-25,6	155,02	1,55	22,48	55,02	0,55	7,98
-31	-23,8	161,33	1,61	23,40	61,33	0,61	8,89
-30	-22	167,83	1,68	24,34	67,83	0,68	9,84
-29	-20,2	174,54	1,75	25,31	74,54	0,75	10,81
-28	-18,4	181,44	1,81	26,32	81,44	0,81	11,81
-27	-16,6	188,56	1,89	27,35	88,56	0,89	12,84
-26	-14,8	195,89	1,96	28,41	95,89	0,96	13,91
-25	-13	203,43	2,03	29,51	103,43	1,03	15,00
-24	-11,2	211,19	2,11	30,63	111,19	1,11	16,13
-23	-9,4	219,18	2,19	31,79	119,18	1,19	17,29
-22	-7,6	227,39	2,27	32,98	127,39	1,27	18,48
-21	-5,8	235,84	2,36	34,21	135,84	1,36	19,70
-20	-4	244,52	2,45	35,46	144,52	1,45	20,96
-19	-2,2	253,44	2,53	36,76	153,44	1,53	22,26
-18	-0,4	262,61	2,63	38,09	162,61	1,63	23,58
-17	1,4	272,03	2,72	39,45	172,03	1,72	24,95
-16	3,2	281,70	2,82	40,86	181,70	1,82	26,35
-15	5	291,62	2,92	42,30	191,62	1,92	27,79
-14	6,8	301,81	3,02	43,78	201,81	2,02	29,27
-13	8,6	312,27	3,12	45,29	212,27	2,12	30,79
-12	10,4	323,00	3,23	46,85	223,00	2,23	32,34
-11	12,2	334,00	3,34	48,44	234,00	2,34	33,94
-10	14	345,28	3,45	50,08	245,28	2,45	35,58
-9	15,8	356,85	3,57	51,76	256,85	2,57	37,25
-8	17,6	368,70	3,69	53,48	268,70	2,69	38,97
-7	19,4	380,85	3,81	55,24	280,85	2,81	40,73
-6	21,2	393,29	3,93	57,04	293,29	2,93	42,54
-5	23	406,04	4,06	58,89	306,04	3,06	44,39
-4	24,8	419,09	4,19	60,78	319,09	3,19	46,28
-3	26,6	432,45	4,32	62,72	332,45	3,32	48,22
-2	28,4	446,13	4,46	64,71	346,13	3,46	50,20
-1	30,2	460,13	4,60	66,74	360,13	3,60	52,23
0	32	474,46	4,74	68,82	374,46	3,74	54,31
1	33,8	489,11	4,89	70,94	389,11	3,89	56,44
2	35,6	504,10	5,04	73,11	404,10	4,04	58,61
3	37,4	519,43	5,19	75,34	419,43	4,19	60,83
4	39,2	535,10	5,35	77,61	435,10	4,35	63,11
5	41	551,12	5,51	79,93	451,12	4,51	65,43
6	42,8	567,49	5,67	82,31	467,49	4,67	67,80
7	44,6	584,22	5,84	84,74	484,22	4,84	70,23
8	46,4	601,31	6,01	87,21	501,31	5,01	72,71
9	48,2	618,77	6,19	89,75	518,77	5,19	75,24
10	50	636,60	6,37	92,33	536,60	5,37	77,83

HC Refrigerant R-290							
Temperature		Absolute pressure			Gauge pressure		
11	51,8	654,81	6,55	94,97	554,81	5,55	80,47
12	53,6	673,40	6,73	97,67	573,40	5,73	83,17
13	55,4	692,38	6,92	100,42	592,38	5,92	85,92
14	57,2	711,75	7,12	103,23	611,75	6,12	88,73
15	59	731,51	7,32	106,10	631,51	6,32	91,59
16	60,8	751,68	7,52	109,02	651,68	6,52	94,52
17	62,6	772,25	7,72	112,01	672,25	6,72	97,50
18	64,4	793,24	7,93	115,05	693,24	6,93	100,55
19	66,2	814,64	8,15	118,16	714,64	7,15	103,65
20	68	836,46	8,36	121,32	736,46	7,36	106,82
21	69,8	858,71	8,59	124,55	758,71	7,59	110,04
22	71,6	881,39	8,81	127,84	781,39	7,81	113,33
23	73,4	904,51	9,05	131,19	804,51	8,05	116,69
24	75,2	928,07	9,28	134,61	828,07	8,28	120,10
25	77	952,07	9,52	138,09	852,07	8,52	123,58
26	78,8	976,53	9,77	141,64	876,53	8,77	127,13
27	80,6	1001,45	10,01	145,25	901,45	9,01	130,75
28	82,4	1026,83	10,27	148,93	926,83	9,27	134,43
29	84,2	1052,68	10,53	152,68	952,68	9,53	138,18
30	86	1079,00	10,79	156,50	979,00	9,79	141,99
31	87,8	1105,79	11,06	160,38	1005,79	10,06	145,88
32	89,6	1133,08	11,33	164,34	1033,08	10,33	149,84
33	91,4	1160,85	11,61	168,37	1060,85	10,61	153,87
34	93,2	1189,12	11,89	172,47	1089,12	10,89	157,97
35	95	1217,88	12,18	176,64	1117,88	11,18	162,14
36	96,8	1247,16	12,47	180,89	1147,16	11,47	166,38
37	98,6	1276,94	12,77	185,21	1176,94	11,77	170,70
38	100,4	1307,24	13,07	189,60	1207,24	12,07	175,10
39	102,2	1338,07	13,38	194,07	1238,07	12,38	179,57
40	104	1369,42	13,69	198,62	1269,42	12,69	184,12
41	105,8	1401,31	14,01	203,25	1301,31	13,01	188,74
42	107,6	1433,73	14,34	207,95	1333,73	13,34	193,44
43	109,4	1466,71	14,67	212,73	1366,71	13,67	198,23
44	111,2	1500,23	15,00	217,59	1400,23	14,00	203,09
45	113	1534,31	15,34	222,54	1434,31	14,34	208,03
46	114,8	1568,96	15,69	227,56	1468,96	14,69	213,06
47	116,6	1604,18	16,04	232,67	1504,18	15,04	218,17
48	118,4	1639,97	16,40	237,86	1539,97	15,40	223,36
49	120,2	1676,34	16,76	243,14	1576,34	15,76	228,63
50	122	1713,30	17,13	248,50	1613,30	16,13	233,99
51	123,8	1750,86	17,51	253,94	1650,86	16,51	239,44
52	125,6	1789,02	17,89	259,48	1689,02	16,89	244,98
53	127,4	1827,79	18,28	265,10	1727,79	17,28	250,60
54	129,2	1867,17	18,67	270,81	1767,17	17,67	256,31
55	131	1907,17	19,07	276,62	1807,17	18,07	262,11
56	132,8	1947,80	19,48	282,51	1847,80	18,48	268,01
57	134,6	1989,07	19,89	288,49	1889,07	18,89	273,99
58	136,4	2030,98	20,31	294,57	1930,98	19,31	280,07
59	138,2	2073,54	20,74	300,75	1973,54	19,74	286,24
60	140	2116,75	21,17	307,01	2016,75	20,17	292,51

Part I : Technical Information

1.Summary

PLATINUM EVO 21



PLATINUM EVO 41

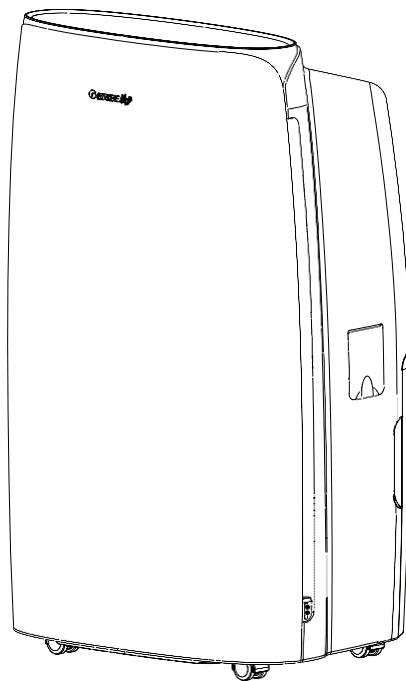

2.Specifications

model			PLATINUM EVO 21
Product Code			
Power Supply	Rated Voltage	V ~	220-240
	Rated Frequency	Hz	50
	Phases		1
Rated Dehumidification Capacity		L/h	0.5
Power Input		W	360
Current Input		A	1.9
Set Humidity Range		%	30/80
Air Flow Volume (H/m/L)		m ³ /h	130/115/105
Fan motor Speed (H/m/L)		r/min	1150/1050/980
Fan motor Power Output		W	8
Fan motor RLA		A	0.16
Fan motor Capacitor		μF	1.2
Fan Type			Centrifugal
Fan Diameter Length (DXL)		mm	Φ180X54.5
Throttling method			Capillary
Fuse Current		A	3.15
Sound Pressure Level (H/m/L)		dB (A)	43/41/39
Sound Power Level (H/m/L)		dB (A)	53/51/49
Climate Type			T1
Isolation			I
moisture Protection			IPX0
Permissible Excessive Operating Pressure for the Discharge Side		mPa	3
Permissible Excessive Operating Pressure for the Suction Side		mPa	1.5
Dimension (WXHXD)		mm	363X577X245
Dimension of Carton Box (LXWXH)		mm	428X311X592
Dimension of Package (LXWXH)		mm	431X314X607
Application Area		m ²	24
Net Weight		kg	15.5
Gross Weight		kg	17
Refrigerant			R290
Refrigerant Charge		kg	0.11
Bucket Capacity		L	3.5/4
Control Type			Electronic
Evaporator	Evaporator Form		Aluminum Fin-copper Tube
	Evaporator Pipe Diameter	mm	Φ7
	Evaporator Row-fin Gap	mm	2-1.3
	Evaporator Coil Length (LXDXW)	mm	225X25.4X209.6
Condenser	Condenser Form		Aluminum Fin-copper Tube
	Condenser Pipe Diameter	mm	Φ7
	Condenser Rows-fin Gap	mm	2-1.3
	Condenser Coil Length (LXDXW)	mm	223X25.4X209.6
Compressor	Compressor manufacturer		Shanghi Hitachi Electrical Appliances Co., Ltd.
	Compressor model		PSA586SV-R1DUN
	Compressor Type		Rotary
	Compressor Power Input	W	327
	Compressor Overload Protector		USP-319-78 or equivalent
	Compressor Oil		5GSD-TB or equivalent
	Compressor LRA.	A	7
Compressor RLA	A	1.65	

The above data is subject to change without notice; please refer to the nameplate of the unit.

model			PLATINUM EVO 41
Product Code			
Power Supply	Rated Voltage	V ~	220-240
	Rated Frequency	Hz	50
	Phases		1
Rated Dehumidification Capacity	L/h		1
Power Input	W		670
Current Input	A		3.00
Set Humidity Range	%		30/80
Air Flow Volume (H/m/L)	m ³ /h		230/195/170
Fan motor Speed (H/m/L)	r/min		1260/1070/900
Fan motor Power Output	W		20
Fan motor RLA	A		0.35
Fan motor Capacitor	μF		2
Fan Type			Centrifugal
Fan Diameter Length (DXL)	mm		Φ192X66
Throttling method			Capillary
Fuse Current	A		3.15
Sound Pressure Level (H/m/L)	dB (A)		48
Sound Power Level (H/m/L)	dB (A)		58
Climate Type			T1
Isolation			I
moisture Protection			IPX0
Permissible Excessive Operating Pressure for the Discharge Side	mPa		3
Permissible Excessive Operating Pressure for the Suction Side	mPa		1.5
Dimension (WXHXD)	mm		396X625X286
Dimension of Carton Box (LXWXH)	mm		448X338X638
Dimension of Package (LXWXH)	mm		451X341X653
Application Area	m ²		48
Net Weight	kg		22.5
Gross Weight	kg		24.5
Refrigerant			R290
Refrigerant Charge	kg		0.15
Bucket Capacity	L		6.5/7
Control Type			Electronic
Evaporator	Evaporator Form		Aluminum Fin-copper Tube
	Evaporator Pipe Diameter	mm	Φ7
	Evaporator Row-fin Gap	mm	2-1.4
	Evaporator Coil Length (LXDXW)	mm	261X25.4X228.6
Condenser	Condenser Form		Aluminum Fin-copper Tube
	Condenser Pipe Diameter	mm	Φ5
	Condenser Rows-fin Gap	mm	3-1.4
	Condenser Coil Length (LXDXW)	mm	261X34.2X228.6
Compressor	Compressor manufacturer		ZHUHAI LANDA COMPRESSION CO., LTD.
	Compressor model		QXD-A121L130
	Compressor Type		Rotary
	Compressor Power Input	W	620
	Compressor Overload Protector		UP3-040
	Compressor Oil		5GSD-TB or equivalent
	Compressor LRA	A	13
Compressor RLA	A	3.0	

The above data is subject to change without notice; please refer to the nameplate of the unit.



3.Outline Dimension Diagram

PLATINUM EVO 21

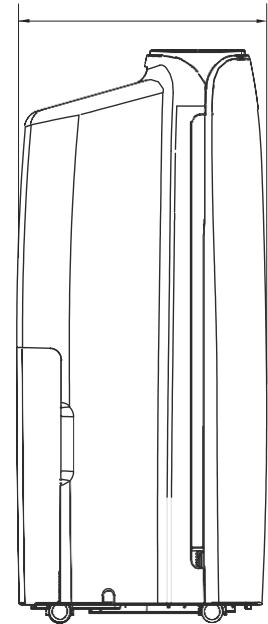
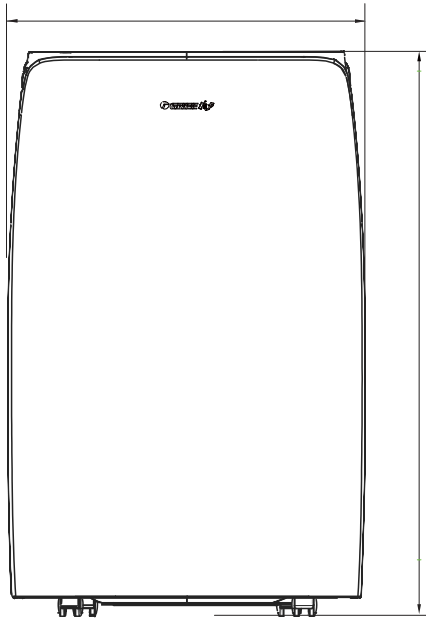

Unit:mm

4.Refrigerant System Diagram

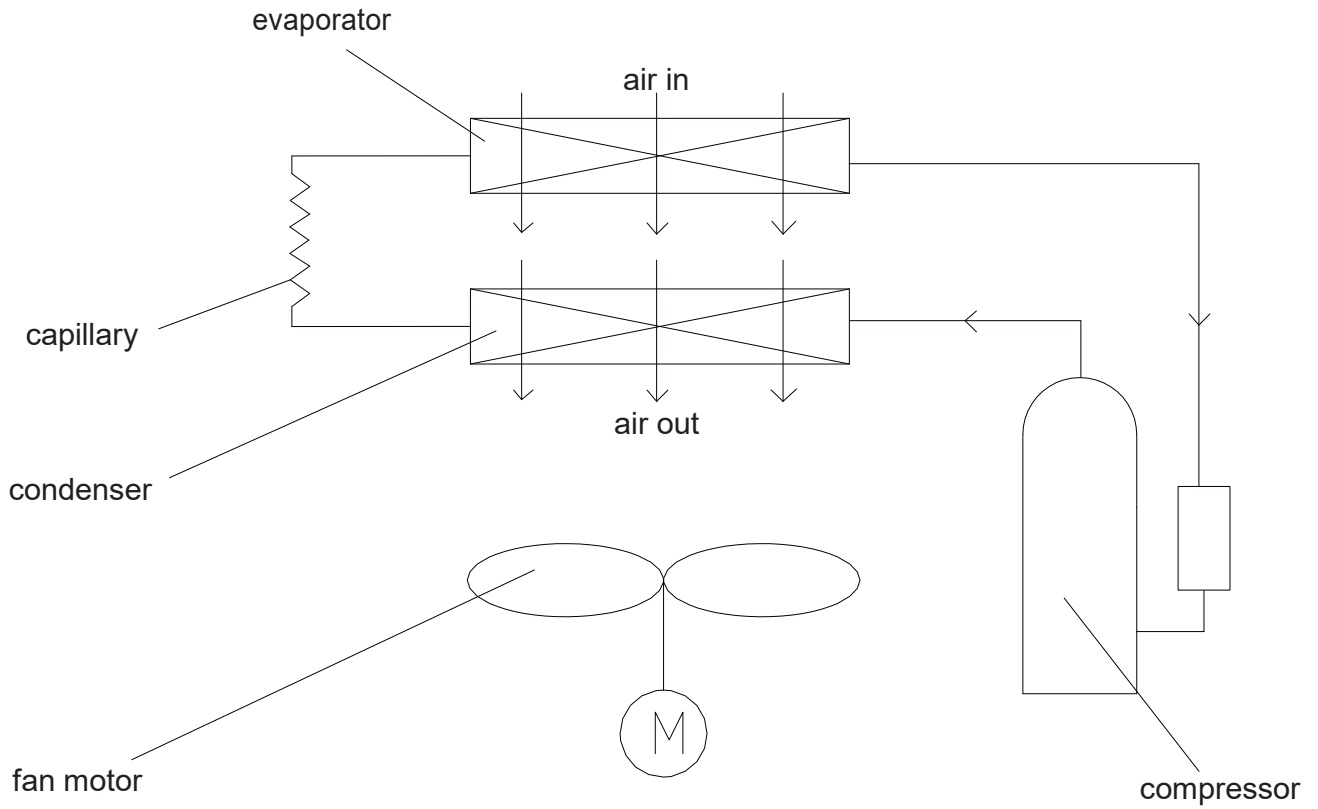

Dehumidifying principle of dehumidifier:

When temperature is decreased to the temperature point of dew, water vapor in humid air will condensate. Dehumidifier is dehumidifying the air by using this principle.

During operation of the system, air will pass through evaporator and condenser in turn and then be discharged due to centrifugal blade. When the air is passing through evaporator, refrigerant will absorb the heat in air to let its temperature decrease to the temperature point of dew, water vapor in air will condensate. Condensate water comes into water tank through water tray, or is discharged directly through drainage hose. The saturated low-temperature air passed through the evaporator will absorb the heat when flowing along the condenser, and then become the dry air. Under normal condition, the nearby air will become warm during operation of dehumidifier.

5. Electrical Part

5.1 Wiring Diagram

● **Instruction**

Symbol	Symbol Color	Symbol	Symbol Color	Symbol	Name
WH	White	GN	Green	CAP	Jumper cap
YE	Yellow	BN	Brown	COmP	Compressor
RD	Red	BU	Blue		Grounding wire
YEGN	Yellow/Green	BK	Black	/	/
VT	Violet	OG	Orange	/	/

Note: Jumper cap is used to determine fan speed and the swing angle of horizontal lover for this model.

PLATINUM EVO 21 - PLATINUM EVO 41

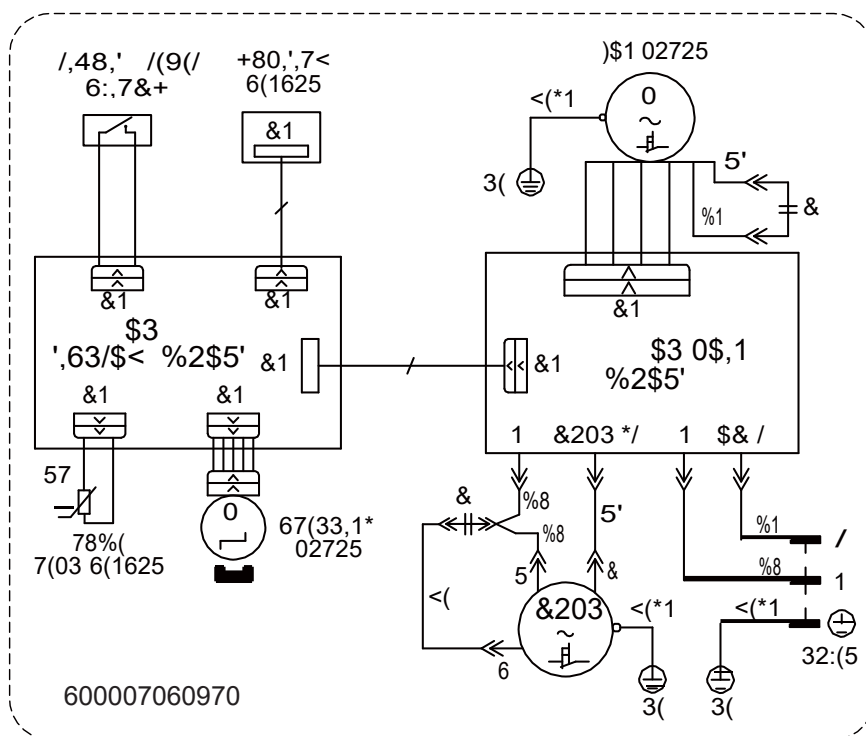

These wiring diagrams are subject to change without notice; please refer to the one supplied with the unit.



5.2 PCB Printed Diagram

Silk Screen on Main Board

• Top view

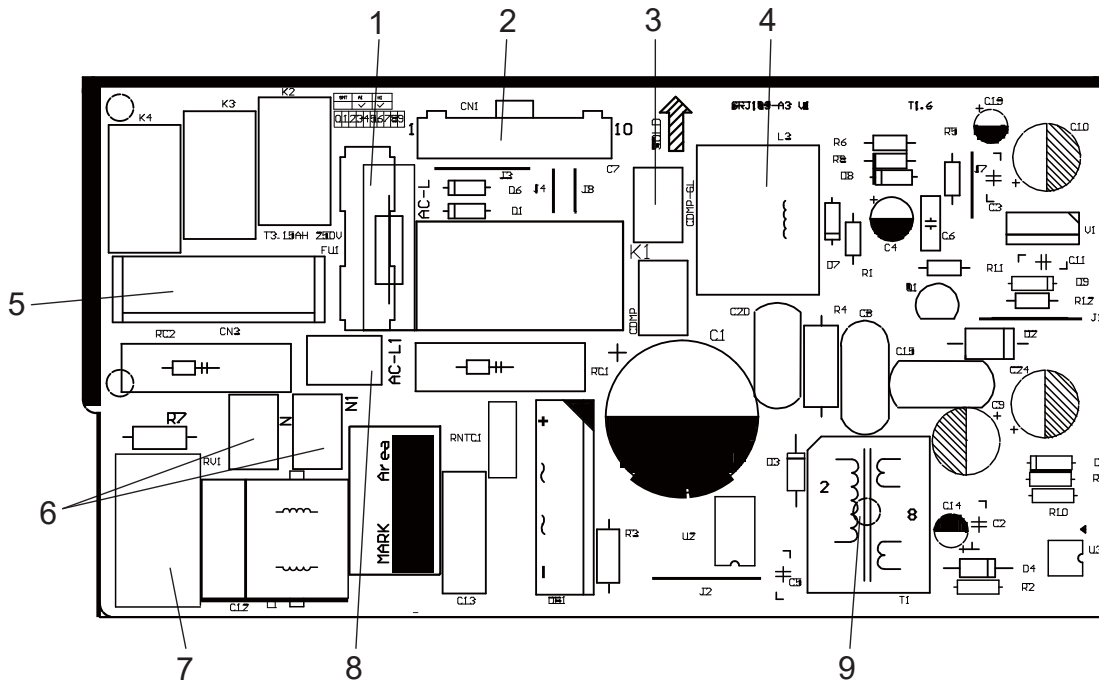

No.	Name	No.	Name
1	Fuse	6	Neutral wire terminal
2	Interface of display board	7	Piezoresistor
3	Wiring terminal of compressor (with overcurrent inspection)	8	Live wire terminal
4	Current mutual-inductor	9	High Frequency Transformer
5	Needle stand for fan		

• Bottom view

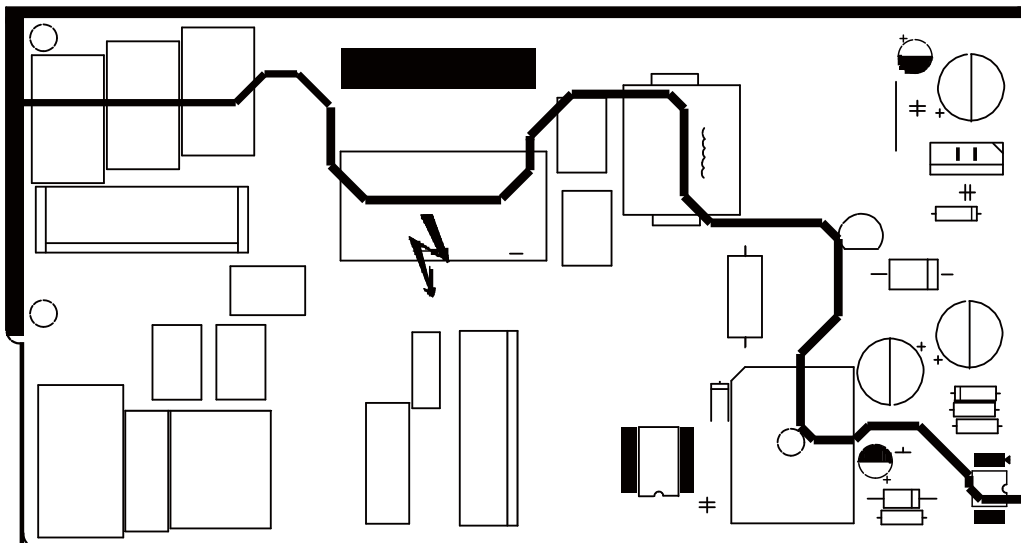

Silk Screen on Display Board

PLATINIUM EVO 21 - PLATINIUM EVO 41

• Top view

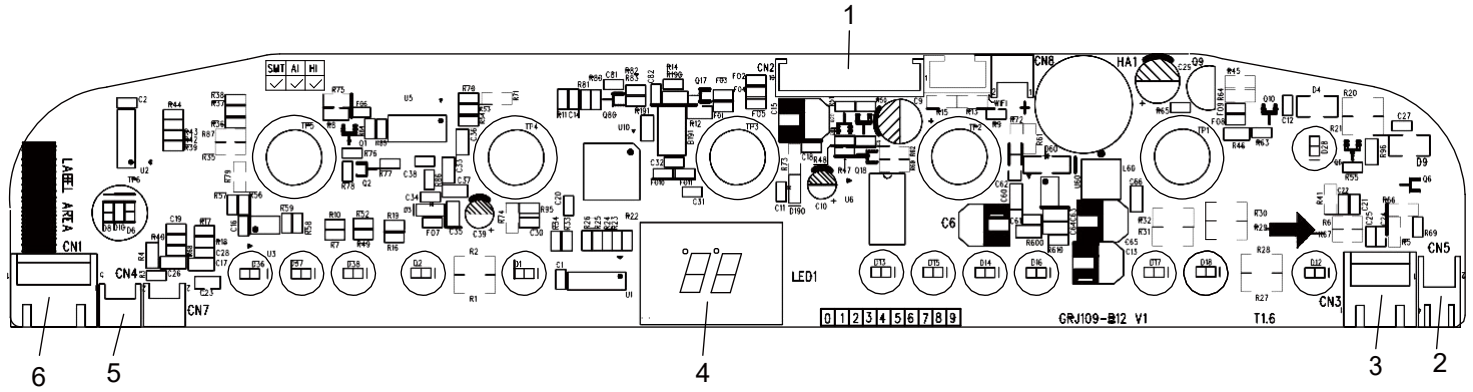

NO.	Name	NO.	Name
1	Interface of wire connect on between boards for connecting main board	4	Nixietube
2	Water level inspection interface	5	Interface of temperature sensor
3	Interface of temperature sensor and humidity sensor	6	Interface of Stepping Motor

• Bottom view

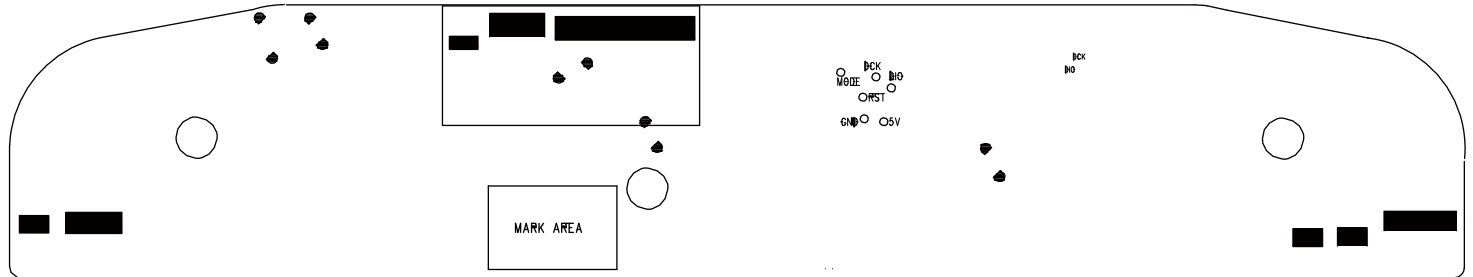

6.Function and Control

6.1 Control panel instruction

PLATINUM EVO 21 - PLATINUM EVO 41

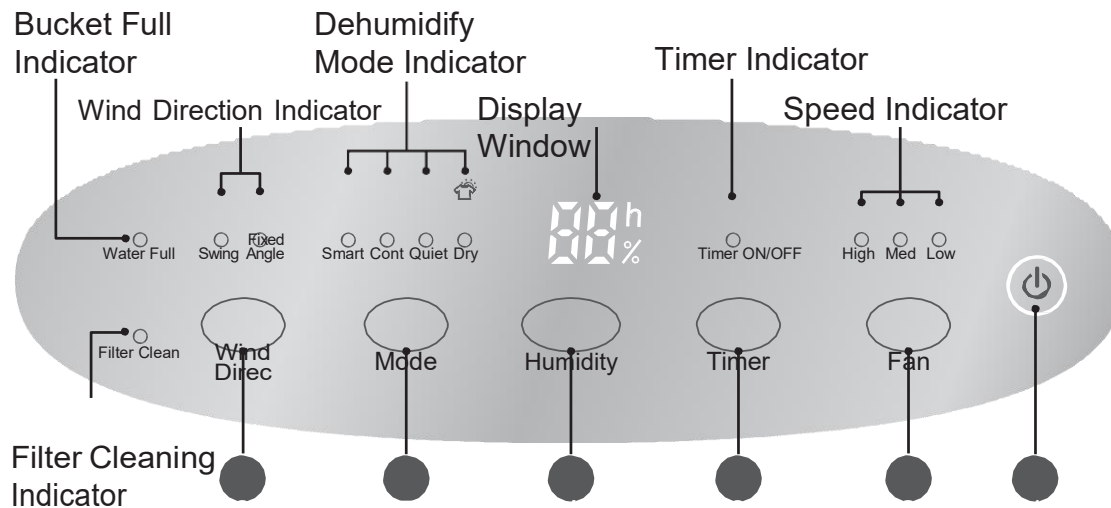

Notes:1.Water bucket must be correctly installed for operation.

2.Do not remove the bucket while unit is in operation.

3.If you want to use drain hose to drain water away, please install the hose according to section "Drainage method".

4.Each time pressing the effective button on the control panel will give out a "beep" sound.

5.When power is connected, power indicator on the control panel will be on and dehumidifier gives out a "beep" sound simultaneously.

(1) ON/OFF Button

Press this button to turn on/off dehumidifier.

(2) Fan Button

Press Fan button can set high, medium or low fan speed. When the corresponding indicator is on, it indicates the current fan speed has been set.

(3) Timer Button

Press Timer button to set timer on or timer off. The timer can be set in 1h increment among 0-24h with each press of Timer button. If hold the Timer button, time will increase rapidly circularly. After timer is set, time will be displayed for 5s and timer indicator will be on.

(4) Humidity Button

Press Humidity button to set your required humidity. If hold Humidity button, humidity can be set in 10% increment among 30%-80% circularly. After that, the set humidity will be displayed for 5s.

(5) mode Button

Press mode button can set 4 kinds of dehumidify mode - Smart, Cont, Quiet and Dry.

- If smart indicator is on, it indicates the unit enters into smart mode. The unit will intelligently select the comfortable humidity for human according to current temperature.
- If cont indicator is on, it indicates the unit enter into continuous dehumidify mode. The unit will always dehumidify only until the humidity is decreased to the inapplicable humidity of human.
- If the quiet indicator is on, the unit enter into quiet mode.The unit will intelligently select the comfortable humidity for human according to current temperature. The unit will operate at the fan speed whose noise is the lowest. The fan speed can't be adjusted.
- If the dry indicator is on, the unit enters into dry mode. After clothes are dried, room humidity will be kept at certain range to prevent mildew. Under dry mode, fan speed and humidity can't be adjusted.

Note:

- Under smart mode and quiet mode, if room humidity is lower than set humidity, or lower than the defaulted comfortable temperature, the unit will stop dehumidifying.
- Under dry mode and cont mode, the humidity can't be adjusted. Under dry mode and quiet mode, fan speed can't be adjusted.

(5) Wind Direc Button

When swing of horizontal louver is needed, press Wind Direc button to select swing or fixed angle. When Swing light of Wind Direc indicator is on, the horizontal louver begins to swing; when Fixed Angle light is on, the horizontal louver stays at current position.



Other Instructions

1. Alarm Warning

If the water bucket is full or the water bucket hasn't been put on the correct position for 3mins, the buzzer will give out sound for 10s for reminding you to empty the water bucket or re-install the water bucket at correct position.

2. Auto Stop

When bucket is full, remove the unit or not placed the unit correctly or the humidity is 10% lower than the set humidity, the unit will stop operation automatically.

3. Memory Function

If power failure, all settings will be memorized. After power recovery, the unit will resume operate according to the memorized settings.

4. Bucket full light

This indicates that bucket is full or removed or not placed correctly.

5. Filter reset

When the indicator of filter clean is on, it needs to clean filter. After filter is cleaned, press Fan button and Humidity button simultaneously and then the indicator of filter clean will be off.

6. Child lock function

Press mode button and Timer button simultaneously for 1s to enter into child lock protection. After pressing any button, LC will be displayed to indicate buttons are locked. Press mode button and Timer button simultaneously for 1s again to release shielding function.

6.2 Introduction of Basic Mode Function

I. Basic Function

1. Smart dry mode

Normal operation condition and process: Under operation status, when energize the unit, turn on the unit or switch mode for the first time, if $T_{amb} \leq 20^{\circ}\text{C}$ set humidity is 60%; when $20^{\circ}\text{C} < T_{amb} \leq 27^{\circ}\text{C}$ set humidity is 50%; when $T_{amb} > 27^{\circ}\text{C}$ set humidity is 40%. If the user adjusts the humidity, the unit will operate in set humidity.

- When $\text{HUMIDITY}_{\text{preset}} \leq \text{HUMIDITY}_{\text{amb}} - 5\%$, compressor will operate and fan will operate in set speed;
- When $\text{HUMIDITY}_{\text{preset}} \geq \text{HUMIDITY}_{\text{amb}} + 10\%$, compressor will stop the fan will operate at low speed
- When $\text{HUMIDITY}_{\text{amb}} - 5\% < \text{HUMIDITY}_{\text{preset}} < \text{HUMIDITY}_{\text{amb}} + 10\%$ and compressor is in operating status, it will operate with condition a; when compressor stops, it will operate with condition b; if the unit is in this condition after turning on, the compressor will be in stoppage status and the the fan will operate at low speed.

2. Continuous dry mode

In continuous dry mode, the complete unit will operate in the following modes and humidity button is invalid.

- When $\text{HUMIDITY}_{\text{amb}} \geq 30\%$, compressor will operate and fan will operate in set speed;
- When $\text{HUMIDITY}_{\text{amb}} \leq 20\%$, compressor will stop and the fan will operate at low speed;
- When $20\% < \text{HUMIDITY}_{\text{amb}} < 30\%$ and compressor is in operating status, it will operate with condition a; when compressor stops, it will operate with condition b; if the unit is in this condition after turning on, the compressor will be in stoppage status and the fan will operate at low speed.

3. Cloth drying mode

After entering cloth drying mode, the compressor operates, the fan operates in high fan speed, humidity and fan button are invalid and fan speed is not displayed. When the complete unit has operated in cloth drying mode for more than 8 hours (when the unit enters temperature sensor error or humidity sensor error, it will stop timing and will resume timing when the error is eliminated) or stops after reaching temperature point (unit stops for exceeding operation conditions), the unit will operate according to the following logic:

Set humidity is 50%, which cannot be adjusted. The complete unit will operate in the following modes:

- When $\text{HUMIDITY}_{\text{preset}} \leq \text{HUMIDITY}_{\text{amb}} - 5\%$, compressor will operate and fan will operate in high speed;
- When $\text{HUMIDITY}_{\text{preset}} \geq \text{HUMIDITY}_{\text{amb}} + 10\%$, compressor will stop and the fan will operate at low speed
- When $\text{HUMIDITY}_{\text{amb}} - 5\% < \text{HUMIDITY}_{\text{preset}} < \text{HUMIDITY}_{\text{amb}} + 10\%$ and compressor is in operating status, it will operate with condition a; when compressor stops, it will operate with condition b; if the unit is in this condition after turning on, the compressor will be in stoppage status and the the fan will operate at low speed.

When turning on the unit after turning it off, or entering cloth drying mode after switching mode, the unit will start operating in cloth drying mode again.

4. Quite dry mode

The fan will operate in low fan speed, fan button is invalid and fan speed is not displayed. Other operation conditions is the same as intelligent drying mode. Under quite dry mode, when $T_{amb} > 34^{\circ}\text{C}$ the following will be performed: ① Compressor stops operation; ② Louver will open once. When $32^{\circ}\text{C} < T_{amb} \leq 34^{\circ}\text{C}$, compressor will keep the previous status. When $T_{amb} \leq 32^{\circ}\text{C}$ compressor operates normally.

II. Protection Functions

1. Compressor protection

After energization, under any situation and after compressor stops, it will restart with 3min delay at least. In operation status, unless there is temperature sensor error, turning off unit with on/off button or water-blow protection, after compressor starts up, it will stop after it runs for 3min at least.

2. Temperature sensor error detection

When ambient humidity sensor occurs error, the compressor stops, fan stops, LED light is off, buttons are invalid and "L1/F1" is displayed.

When two sensors occur error, "F1, L1, F2" is displayed alternatively to remind user for repairing.

3. Water full protection

In operating status, the water full protection will occur when the water level of water bucket is exceeded, water bucket is removed or water bucket is not placed well. The compressor stops and fan will stop after 3min. The buzzer will stop after it gives out a beep for 10s, water full indicator will blinks and all the buttons are invalid except ON/OFF button; When the water level or placing of water bucket resumes to normal, water full protection signal is eliminated, water full indicator is off, buzzer stops giving a beep, fan operates as previous set speed, and the compressor resumes to normal operation after stopping for 3min.

In unit off status, if water full protection occurs, water full indicator will blink continuously and buzzer will stop after it gives out a beep for 10s. compressor and fan do not operate and all buttons are invalid.

4. Freeze protection

During operation, when freeze protection is detected, the compressor stops operation, fan operates in high speed forcibly; when freeze protection is eliminated, fan speed button will resume valid, fan operates as previous set speed, and the compressor resumes to normal operation after stopping for 3min.

III. Other Functions

1. Panel buttons

“ON/OFF” button: turn on or turn off the unit.

“Timer” button: set timer within 0~24h; hold on pressing Timer button for 1S, timer time will increase by one hour per 400MS.

“Humidity” button: adjust humidity (adjust humidity continuously and circulative in 30% -40% -50% -60% -70% -80%); hold on pressing Humidity button for 1S, humidity value will increase by 10%RH per 400MS.

“Mode” button: set drying mode (smart, continuous, quiet, cloth drying).

“Fan” button: adjust fan speed (high, medium, low).

“Wind direction” button: adjust louver (swing or fixed-angle).

(PLATINUM EVO 21 - PLATINUM EVO 41)

“Mode” indicator: display current operation mode (smart, cont, quiet and dry);

“Fan” indicator: display current fan speed (high, medium, low) (fan speed is not displayed in quiet and cloth drying mode);

“Timer” indicator: this indicator is on when there is a timer; this indicator is off when there is no timer;

“Fixed angle” indicator: display swing status; when this is no swing, fixed angle indicator is on;

“Swing” indicator: display swing status; when this is swing, swing indicator is on;

“Filter cleaning” indicator: when the fan has operated accumulatively for 250 hours, this indicator is on; after pressing filter combination buttons to eliminate filter protection, this indicator is off;

“Water full protection” indicator: this indicator will blink when water full protection occurs;

“Standby/operation” indicator: red light is displayed in standby mode (always on); white light is displayed in operating status (always on).

3. Timer control

0~24h timer can be set with one hour as a level; timer off can be set in unit on status and timer on can be set in unit off status.

4. Display of nixie tube

a. In operation status, nixie tube displays current humidity; press “humidity” button to display set humidity; it will resume to display current ambient humidity after 5s:

Ambient humidity displaying range is 1%~99%. It will display 99% if humidity exceeds 99%. Within 15s after turning on the unit, current set humidity will be displayed in smart and quiet mode; 50% will be displayed in cloth drying and continuous mode; after 15s, current ambient temperature will be displayed and the value will be updated every 5s.

b. Under any situation, if temperature sensor or humidity sensor occurs error, “F1”, “F2” or “L1”, “E5”, “H3”, “F0” will be displayed. Timer indicator, button background indicator, operation mode indicator, fan indicator, filter indicator will not display. Error code will not be displayed in unit off status.

c. “E5” will be displayed in overcurrent protection; “H3” will be displayed in overload protection; “F0” will be displayed in refrigerant leakage protection; compressor protection and freeze protection will not be displayed.

d. When several error codes will be displayed, the error codes will be displayed alternatively in every 3s.

5. Filter warning function

When the fan has operated accumulatively for 250 hours, filter indicator is on to remind user to clean the filter; user can press “filter reset” button to clear timing and then filter indicator will be off.

In unit off status, the filter indicator is off; filter cleaning time will be recorded once in every 30min.

6. Buzzer

During energizing or receiving valid button signal, the buzzer will give out a beep.

7. Factory default setting

Fan speed: Low.

Mode: smart dehumidifying mode.



Part II : Maintenance

7. Notes Maintenance

Safety Precautions:

Important!

Please read the safety precautions carefully before maintenance.

The following contents are very important for installation and maintenance.

Please follow the instructions below.

- The maintenance must accord with the instructions.
- Comply with all national electrical codes and local electrical codes.
- Pay attention to the warnings and cautions in this manual.
- Be cautious during maintenance. Prohibit incorrect operation to prevent electric shock and other accidents.

Refrigerant Safety Precautions:

1. Avoid contact between refrigerant and fire as it generates poisonous gas. Recycle the refrigerant inside the unit completely before welding pipes.
2. Apply specified refrigerant only. Never have it mixed with any other refrigerant. Never have air remain in the refrigerant line as it may lead to rupture or other hazards.
3. If refrigerant is leaking seriously, it may cause suffocation or explosion. When using the combustible refrigerant, please put the unit at ventilated place.
4. Never touch the refrigerant piping or compressor without wearing glove to avoid scald or frostbite.

Improper installation may lead to fire hazard explosion, electric shock or injury.



Warnings

Electrical Safety Precautions:

1. Cut off the power supply before maintenance.
2. Specialized circuit must be applied; prohibit sharing the same circuit with other electric appliances; protection switch must be installed.
3. Have the unit adequately grounded. The grounding wire can't be used for other purposes.
4. The live wire, neutral wire and grounding wire of power supply must be corresponding to the live wire, neutral wire and grounding wire of the dehumidifier.
5. The power cord can't be pressed by hard objects.
6. If the power cord or connection wire is not long enough, please get the specialized power cord or connection wire from the manufacture or distributor. Prohibit prolong the wire by yourself.
7. Replace the fuse with a new one of the same specification if it is burnt down; don't replace it with a copper wire or conducting wire.
8. Use the power supply with same voltage and frequency as shown in rating label.
9. Do not pull out the power plug when the unit is operating to avoid damaging the circuit.
10. Do not place anything at the top of dehumidifier; ensure the air outlet or air inlet is not blocked; do not use the unit near wall and curtain.
11. Do not use heating equipment around the unit.



Appliance filled with flammable gas R290.



Before install and use the appliance, read the owner's manual first.



Before install the appliance, read the installation manual first.



Before repair the appliance, read the service manual first.

The Refrigerant

- To realize the function of the air conditioner unit, a special refrigerant circulates in the system. The used refrigerant is the fluoride R290, which is specially cleaned. The refrigerant is flammable and odorless. Furthermore, it can lead to explosion under certain conditions.
- Compared to common refrigerants, R290 is a nonpolluting refrigerant with no harm to the ozone layer. The influence upon the greenhouse effect is also lower. R290 has got very good thermodynamic features which lead to a really high energy efficiency. The units therefore need a less filling.
- Please refer to the nameplate for the charging quantity of R290.

WARNING :

- Appliance filled with flammable gas R290.
- Appliance shall be installed, operated and stored in a room with a floor area larger than 4m².
- The appliance shall be stored in a room without continuously operating ignition sources. (for example: open flames, an operating gas appliance or an operating electric heater.)
- The appliance shall be stored in a well-ventilated area where the room size corresponds to the room area as specified for operation.
- The appliance shall be stored so as to prevent mechanical damage from occurring.
- Ducts connected to an appliance shall not contain an ignition source.
- Keep any required ventilation openings clear of obstruction.
- Do not pierce or burn.
- Be aware that refrigerants may not contain an odour.
- Do not use means to accelerate the defrosting process or to clean, other than those recommended by the manufacturer.
- Servicing shall be performed only as recommended by the manufacturer.
- Should repair be necessary, contact your nearest authorized Service Centre. Any repairs carried out by unqualified personnel may be dangerous.
- Compliance with national gas regulations shall be observed.
- Read specialist's manual.

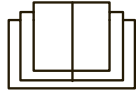

1 Safety Principle of Maintenance

1. The maintenance spot must have good ventilation. Do not close the door or the window.
2. Do not use naked flame, including welding, smoking. Do not use mobile phone. Tell the user not to cook with naked flame.
3. Take antistatic measures, including wearing pure cotton clothes and gloves etc.
4. If flammable refrigerant leakage is found during maintenance, it is a must to reinforce ventilation, and block the leak source.
5. During maintenance, it is necessary to keep the spot safe when fetching the lacked spare parts.
6. It is necessary to keep the case of the air unit grounded during maintenance.
7. When carrying the refrigeration steel cylinder to the user's place, the refrigeration inside shall not exceed the rated value. The steel cylinder must be vertical and away from the heat source, fire source, radiation source and electric appliance.
8. It is necessary to carry the unit to the service center for maintenance, when
 - (1) inner refrigerant pipe must be welded;
 - (2) disassembling the heat exchanger; e.g. replacing chassis of outdoor unit, removing condenser;
 - (3) replacing compressor or components of cooling system.
9. The maintenance unrelated to refrigerant vessel, inner refrigerant pipe and cooling component can be performed in the user's place, including cleaning the cooling system and sludging.
10. Ensure that the density tester is working during maintenance.
11. Ensure there is necessary safety precaution and emergency measures on the spot. Put suitable fire extinguishers (CO₂ or dry powder) in the nearest area.
12. There must be natural ventilation in the maintenance spot.
13. The maintenance staff shall take safety actions.
14. Paste suitable signs such as "No Smoking" and "No Entry".

2 Preparation before Maintenance

1. Inspection of Environment

- (1) Ensure that electric product with radiation is power off in the maintenance area. All the persons in the room shall turn off the mobile phone.
- (2) Check if there is refrigerant leakage in the maintenance area. Ensure that all the leak testers are suitable for this air conditioner.
- (3) Ensure that the room area reaches the requirement.
- (4) Check if the maintenance area is ventilated. Keep the room ventilated.

2. Inspection of unit

- (1) Ensure that the unit is reliably grounded.
- (2) Ensure that the power supply of the unit is cut off. Discharge the electricity of the capacitor. If power supply is necessary, perform leak test to prevent the potential danger.

3. Inspection of Maintenance Equipment

- (1) Check if the maintenance equipment is suitable for the refrigerant. Only the special equipment recommended by the unit supplier can be used.
- (2) The set alarm density of the leak tester shall not be higher than 25% of the LEL. The tester must keep operating during maintenance.

4. Leak Test before Maintenance

- (1) After cutting off the power supply, perform leak test with the recommended leak detector or density tester (pump suction type) (ensure the equipment is calibrated; leakage ratio of leak detector is 2g/year.)

Note: do not use resolvent with chlorine in case causing corrosion of the steel pipe.

- (2) If leakage is found, remove all fire source ensure good ventilation of the area.

5. Check List

No.	Check information	Result	Yes/No
1	Maintenance equipment is complete		
2	Persons in the maintenance area turn off the mobile phone.		
3	Power supply of tools is 2m away.		
4	Density tester can be used.		
5	Other tools are normal.		
6	Maintenance staffs are qualified.		
7	The spare parts are provided by the manufacturer and qualified.		
8	The unit needed to be serviced is under safe state.		
9	The wire of power socket is reliably connected.		
10	There is natural ventilation in maintenance area.		
11	There is no operating electric appliance or naked flame within 2m of Maintenance area.		

3 Maintenance Cautions

If it is necessary to replace components, all the components used shall be made by manufacturer. Otherwise, the supplier shall not bear the responsibility.

1.Maintenance of Electrical Parts

- (1) Replace the power cord and connecting wire with that of the same specification.
- (2) When inspecting the circuit with power on, check if there is electric leakage for the metal component such as evaporator or condenser. During inspection, do not touch the circuit so as to prevent electric shock.
- (3) When inspecting the capacitor, ensure that the maintenance area is well ventilated. After conforming there is no refrigeration leakage, discharge electricity of capacitor.
- (4) Before replacing the component, cut of the power supply of the unit.
- (5) Cut off the power before disconnecting and connecting the wire. Disconnect the live wire first and then ground wire.
- (6) During maintenance, do not remove the protective component. Use the component of same supplier and specification.
- (7) When servicing the hermetic parts, cut of the power of the unit before opening the sealing cover. If it is necessary to use power supply, perform leak test to prevent potential danger.
- (8) Do not replace the case which may affect the protective grade.
- (9) Ensure that the sealing material is not degraded and that it can prevent entry of flammable gas. The parts used for replacement must reach the requirement of the supplier.

2.Maintenance of Refrigeration System

- (1) Do not lengthen or cut the connecting pipe.
- (2) If the system component (such as evaporator, condenser, compressor, pipe) is needed to be serviced, discharge the refrigerant of the system completely before maintenance.
- (3) The parts used for replacement must be made by manufacturer.
- (4) It is necessary to perform leak test before and after maintenance and ensure there is no leakage.

(5).Replace electric box

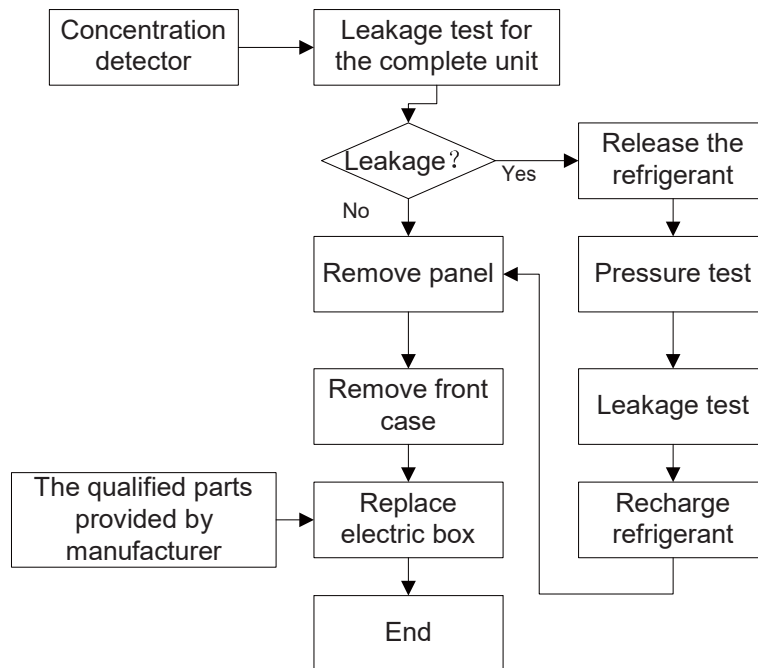

(6).Replace main board

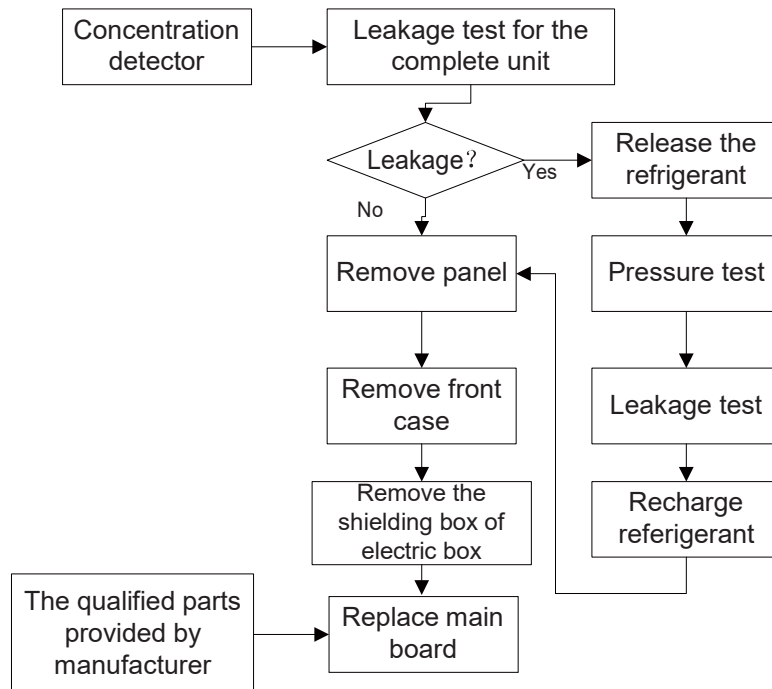

(7).Replace pipeline or repair welding

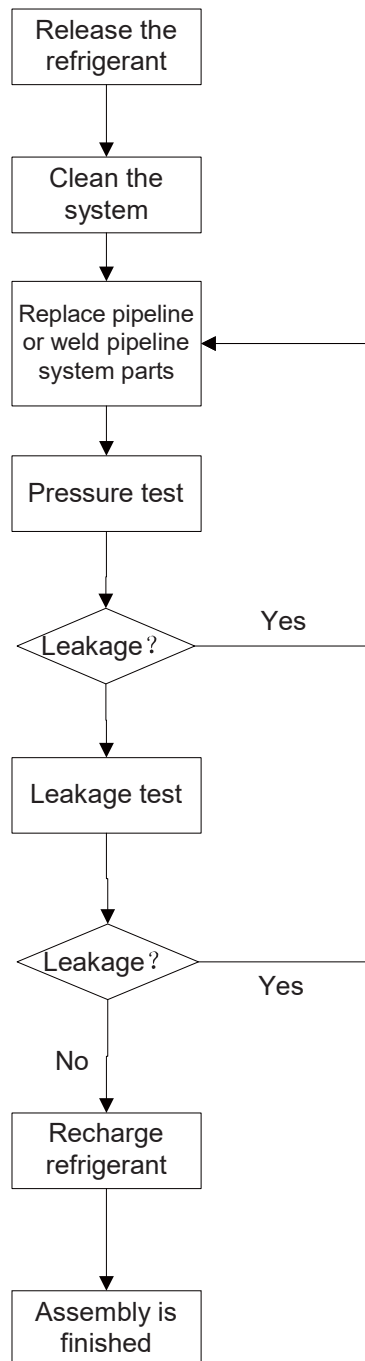

Main Tools for Maintenance

<p>1. Electroprobe</p> 	<p>2. Screw driver</p> 	<p>3. Open-end wrench, inner hexagon spanner</p> 
<p>4. Electronic leakage detector</p> 	<p>5. Vacuum pump</p> 	<p>6. Pressure meter</p> 
	<p>7. Universal meter</p> 	<p>8. Soldering appliance, refrigerant container</p> 

8.Maintenance

8.1 Error code

No.	malfunction Name	Nixie tube display	Unit status	Possible Causes
1	Inspection malfunction of ambient temperature	F1	Compressor and fan motor stop. Buttons are invalid.	1.Connection of temperature/humidity sensor is poor 2.Temperature/humidity sensor is damaged 3.Display board is damaged
2	Humidity inspection malfunction	L1		
3	malfunction of tube temperature sensor	F2	The compressor stops and fan motor keeps on running. Buttons are invalid.	1.Temperature sensor on the evaporator is loosen or is poorly connected with the terminal of display board. 2.Some element of display board may have been put upside down and cause short circuit. 3. Temperature sensor on the evaporator is damaged (Please refer to Checking Table for Temperature Sensor Resistance). 4. Display board is damaged.
4	Freon-lacking protection	F0		1.Refrigerant is leaking. 2.System is blocked.
5	Overload protection	H3		1.Ambient operation condition is bad. 2.The evaporator and condenser are blocked with filth. 3.The system is abnormal.
6	Overcurrent protection	E5	1. Relay is short-circuited or broken-circuited; 2. Operation environment condition is formidable high temperature and high humidity.	

8.2 Malfunction Detection Flowchart

Malfunction of temperature sensor F1, L1

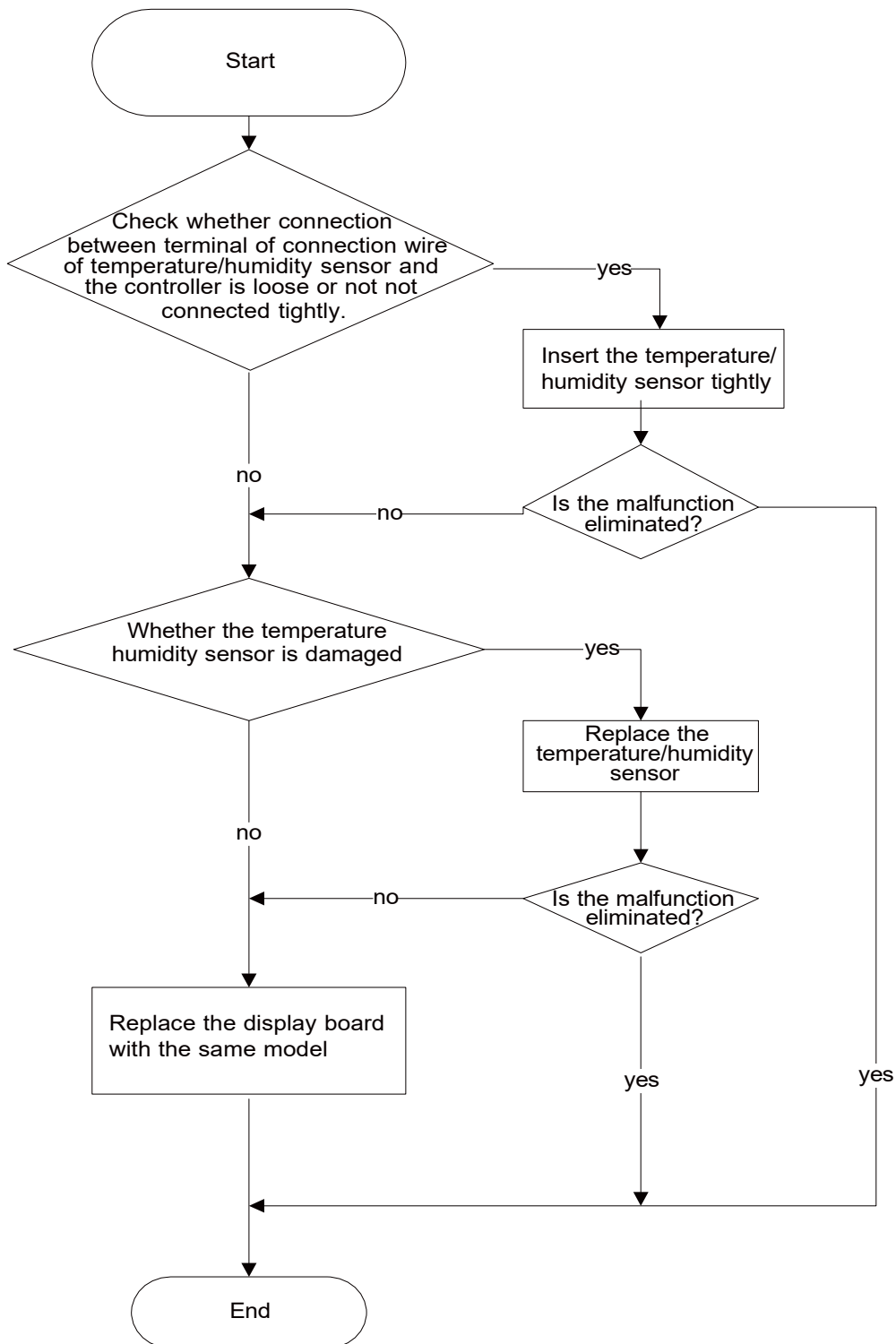

2. Malfunction of temperature sensor F2

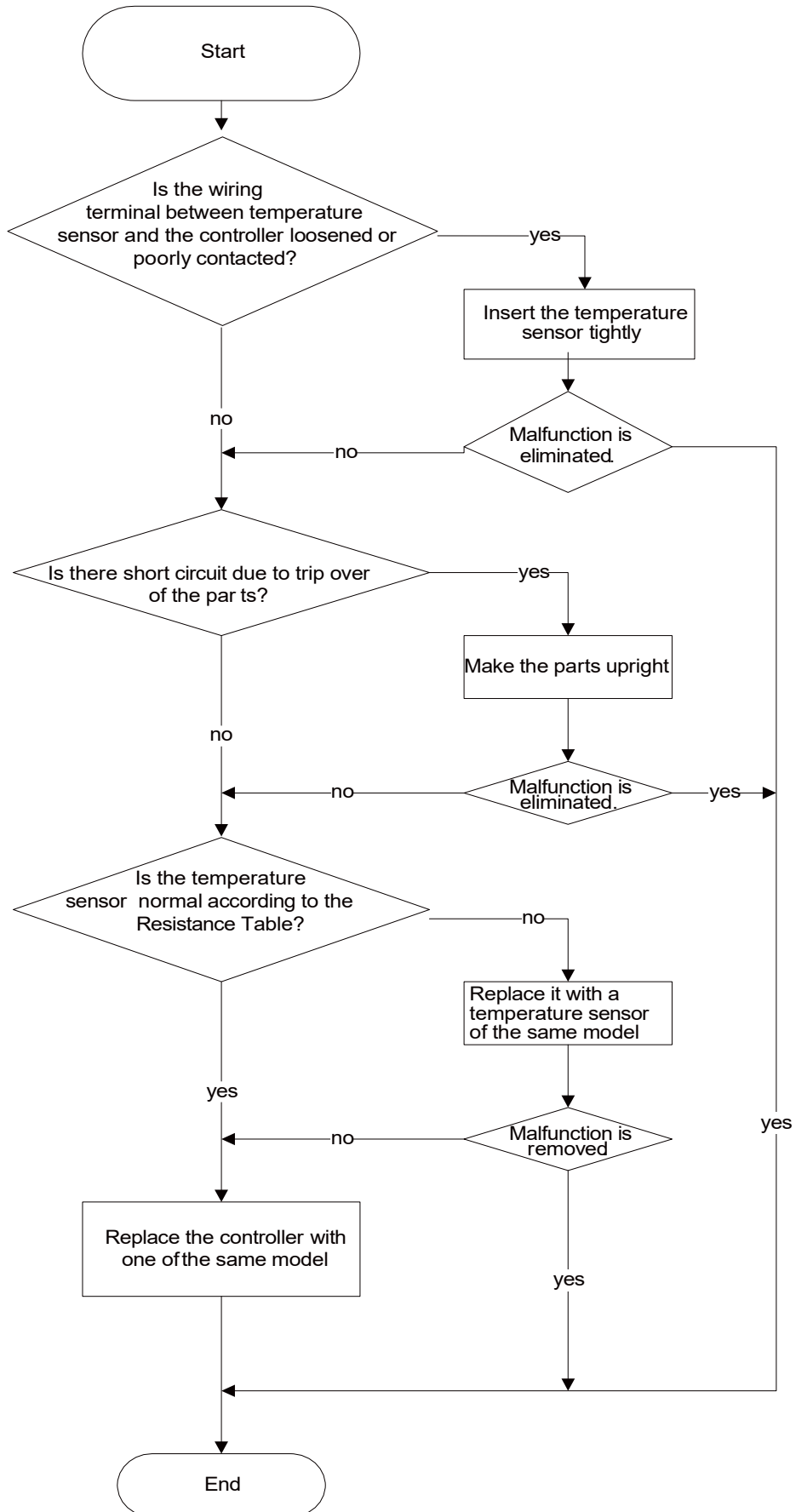

8.3 Maintenance method for common malfunction

1. The unit can not start up

Possible causes	Discriminating method (dehumidifier status)	Troubleshooting
No power supply, or poor connection for power plug	After energization, operation indicator isn't bright and the buzzer can't give out sound	Confirm whether it's due to power failure. If yes, wait for power recovery. If not, check power supply circuit and make sure the power plug is connected well.
Poor connection between wiring terminals	Power indicator is not on after the unit is energized	Check the circuit according to wiring diagram and connect wire properly; ensure each wiring terminal contact firmly
There is electric leakage in the unit	Circuit breaker jump off immediately after the unit is energized	make sure the unit is properly grounded; make sure the wiring is correct; Check if the insulating layer of wires inside the unit and power cord is in good condition; if the layer is broken, please replace it.
Placing position of water tank is not correct. Water is removed or the water is full.	Wall-full indicator flashes.	make sure the water tank is placed correctly.

2. Poor dehumidifying effect

Possible causes	Discriminating method (dehumidifier status)	Troubleshooting
Set humidity is irrational	Observe the displayed set humidity	Adjust set humidity
Filter is blocked	Check the filter to see it's blocked	Clean the filter
Placing position of water tank is improper.	Check whether there're obstacles around the dehumidifier blocked the air outlet.	make sure there're no obstacles around the dehumidifiers.
Refrigerant is leaking	Air outlet temperature is lower than normal temperature during dehumidifying period.	Find out the cause of leakage and solve the problem; charge refrigerant
malfunction of capillary	Air outlet temperature is lower than normal temperature during dehumidifying period. If the refrigerant isn't leaking, some parts of capillary is blocked.	Replace capillary
malfunction of fan	Fan can't operate.	Refer to point 3 of maintenance method for details
malfunction of compressor	Compressor can't operate	Refer to point 4 of maintenance method for details

3. Fan can't operate

Possible causes	Discriminating method (dehumidifier status)	Troubleshooting
Wrong wire connection, or poor connection	Check the wiring status according to circuit diagram	Connect wires according to wiring diagram to make sure all wiring terminals are connected firmly
Needle stand of connection wire between mainboard and display board is loosened	Check if the needle stand is loosened	Reinsert the needle stand firmly
Fan capacitor is broken	Test the voltage between two ends of fan capacitor with universal meter and the value is 0	Replace fan capacitor
Power supply voltage is too low or too high	Test the power supply voltage with universal meter and the value is too high or too low	Apply voltage regulator
Fan is broken	The above situation is normal but the fan does not operate	Repair or replace the fan

4. Compressor can't operate

Possible causes	Discriminating method (dehumidifier status)	Troubleshooting
Wrong wire connection, or poor connection	Check the wiring status according to circuit diagram	Connect wires according to wiring diagram to make sure all wiring terminals are connected firmly
Compressor relay on the mainboard is broken or the compressor needle stand is loosened	Check if the relay is sucked in cooling mode	Replace the mainboard with the same model
Capacity of compressor is damaged	After tuning on the unit, the unit can't dehumidify. Use universal meter to measure the resistance value of two contact points of capacitor. If the resistance value is too big or 0, the capacitor is damaged.	Replace the compressor
Power voltage is a little low or high	After turning on the unit, dehumidifying effect is poor or compressor is turned on or off frequently. Use universal meter to measure the power supply voltage directly	The fluctuation of voltage is 10% rated power. If the power is too low or too high, you are suggested to equip wit voltage regulator.
Coil of compressor is burnt out	There is no dehumidifying effect after turning on the unit; test the resistance of the wiring poles of compressor with universal meter; if the resistance is infinite or zero, it means it is broken	Repair or replace compressor
Cylinder of compressor is blocked	The dehumidifying effect is poor after turning on the unit; the noise of compressor is big and the compressor is hot	Repair or replace compressor

5. Water leakage

Possible causes	Discriminating method (dehumidifier status)	Troubleshooting
Drainage pipe hasn't been installed correctly.	Water is coming out from indoors.	Eliminate the blocking objects inside the drainage channel.

6. Abnormal sounds and vibration

Possible causes	Discriminating method (dehumidifier status)	Troubleshooting
There is abnormal sound in some parts when just turning on or turning off the unit	There's the sound of "PAPA"	Normal phenomenon. Abnormal sound will disappear after a few minutes.
There is abnormal sound of refrigerant flowing when just turning on or turning off the unit	Water-running sound can be heard	Normal phenomenon. Abnormal sound will disappear after a few minutes.
There is touching sound of foreign objects or parts inside the unit	The unit gives out abnormal sound	Take out the foreign objects; adjust the position of each part inside the unit; tighten the connection screws; apply some damping gum on the touching parts
Abnormal shake of compressor	Outdoor unit gives out abnormal sound	Adjust the support foot mat of compressor, tighten the bolts
Abnormal sound inside the compressor	Abnormal sound inside the compressor	If add too much refrigerant during maintenance, please reduce refrigerant properly. Replace compressor for other circumstances.

9.Exploded View and Parts List

PLATINUM EVO 21

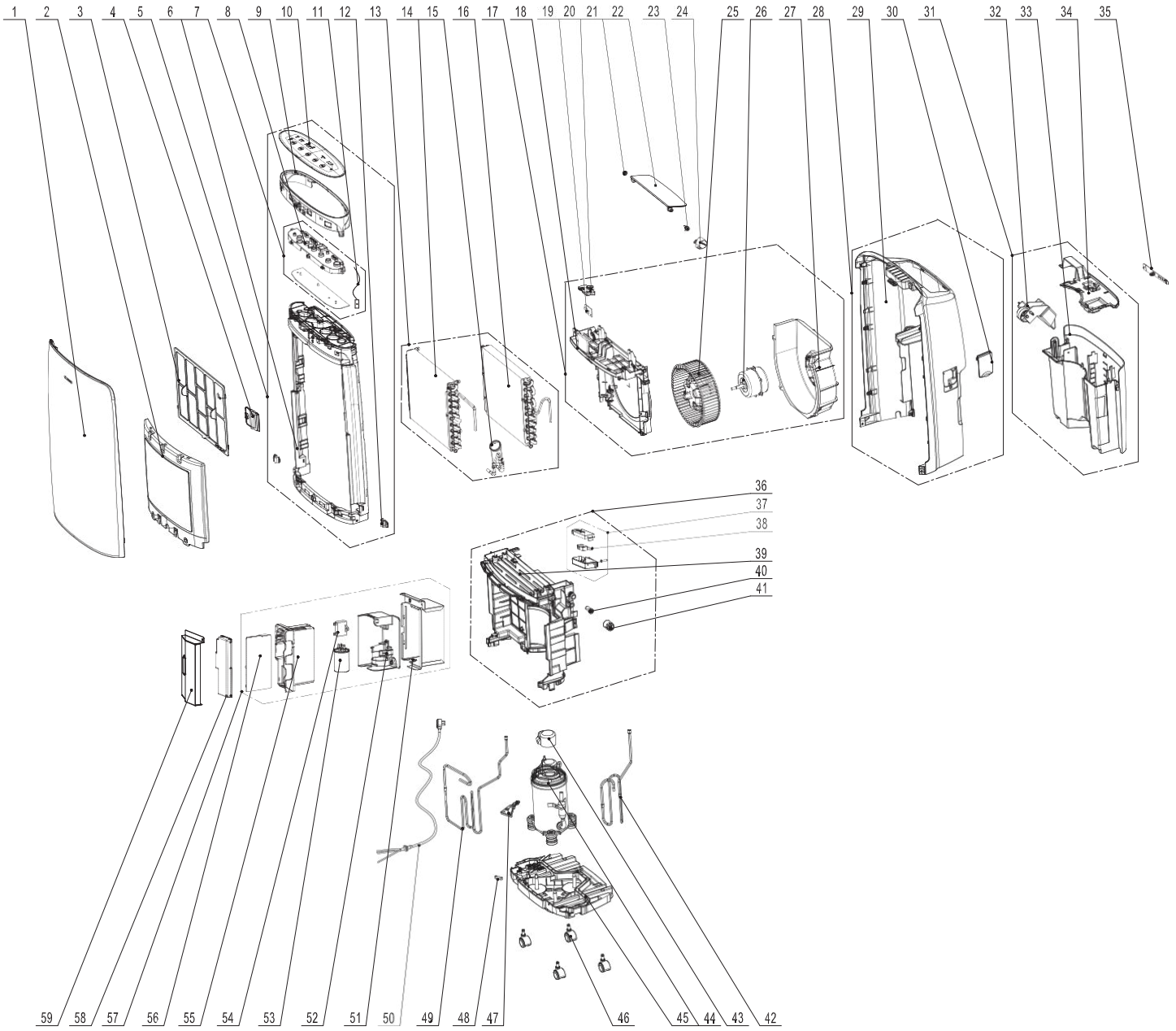

The component picture is only for reference; please refer to the actual product.

No.	Description	Part Code	Qty
		PLATINUM EVO 21	
Product Code			
1	Shield Sub-Assy	22206581	1
2	Lower Sealplate	26116534	1
3	Filter Sub-Assy	11126538	1
4	Baffle Plate	26116537	1
5	Supporting Strip Sub-Assy	00019300003	1
6	Supporting Strip	24216509	1
7	Display Board	30561072	1
8	Display Box	20116075	1
9	Decorative Circle	20196057	1
10	Top Plate	01256506P	1
11	Temperature Sensor	390000594	1
12	Front Panel Clip	26256002	2
13	Heat-exchange Equipment	011004000014	1
14	Evaporator Sub-Assy	01036109	1
15	Capillary Sub-Assy	03006199	1
16	Condenser Sub-Assy	01136248	1
17	Air Flue Assy	00001100043	1
18	Diversion Circle	10376236	1
19	Detecting Plate	30070064	1
20	Cover Plate (Temperature & Humidity Sensor)	26116222	1
21	Air Guide Bushing	1054420302	1
22	Guide Louver	10516091	1
23	Crank	10582070	1
24	Stepping motor	1521200601	1
25	Centrifugal Fan	1031606501	1
26	Fan motor	1501607103	1
27	Propeller Housing	22206102	1
28	Rear Cover Assy	22206556	1
29	Rear Case	22206562	1
30	Cover of drainage hole	22246097	1
31	Water Tank Assy	20186567	1
32	Float meter Sub-Assy	2611652605	1
33	Water Tank	20186561	1
34	Water Tank Cover	22246528	1
35	Tieline of Power Cord	71020001	1
36	Water Tray Assy	0127651502	1
37	Liquid Level Switch Sub-assy	00019400004	1
38	Lnching Switch	45016514	1
39	Water Tray	20186562	1
40	Rubber Plug	76716054	1
41	Cover of drainage hole	22246097	1
42	Inhalation Tube Sub-Assy	03001000051	1
43	Covering Plate	01225600001	1
44	Compressor and Fittings	00106546	1
45	Chassis Sub-Assy	01206521	1
46	Castor	24236554	4
47	Baffle Plate	01356000260	1
48	Cable Clamp	71010312	1
49	Discharge Tube Sub-Assy	03001300291	1
50	Power Cord	4002028602	1
51	Electric Box Sub-Assy	01700700082	1
52	Insatallation Box	20017700003	1
53	Capacitor CBB65	3300002237	1
54	Capacitor CBB61S	33010098	1
55	Electric Controller Box	20126026	1
56	main Board	30131489	1
57	Electric Box Assy	100002063850	1
58	Seal Cover	20126517	1
59	Electric Box Cover	4002028632	1

Above data is subject to change without notice.

PLATINUM EVO 41

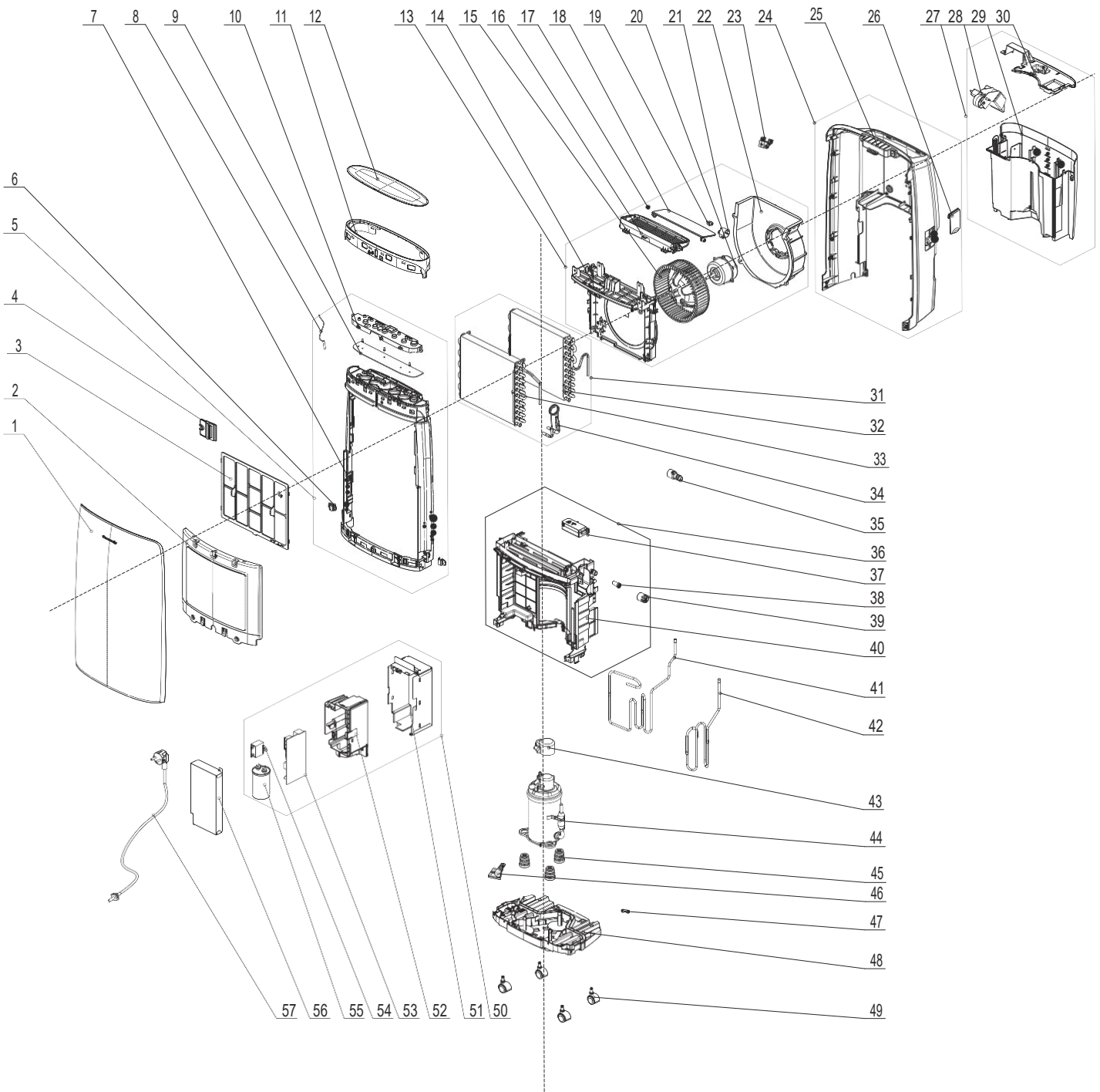

The component picture is only for reference; please refer to the actual product.

No.	Description	Part Code	Qty
		PLATINUM EVO 41	
Product Code			
1	Shield Sub-Assy	00016700003	1
2	Lower Sealplate	26116535	1
3	Filter Sub-Assy	11126030	1
4	Baffle Plate	01356000260	1
5	Supporting Strip Sub-Assy	24216512	1
6	Front Panel Clip	26256002	2
7	Supporting Strip	24216510	1
8	Temperature Sensor (20KT)	390000595	1
9	Display Board	300001060384	1
10	Display Box	20116075	1
11	Decorative Circle	20196058	1
12	Top Plate	01256507B	1
13	Air Flue Assy	00001100048	1
14	Diverson Circle	10376059	1
15	Centrifugal Fan	10316074	1
16	Front Grill	22416059	1
17	Air Guide Bushing	1054420302	1
18	Guide Louver	10516092	1
19	Crank	10582070	1
20	Fan motor	15016072	1
21	Stepping motor	1521200601	1
22	Propeller Housing	22206559	1
23	Detecting Plate	30070038	1
24	Rear Cover Assy	22206557	1
25	Rear Case	22206560	1
26	Cover of drainage hole	22246533	1
27	Water Tank Assy	20186566	1
28	Float meter Sub-Assy	2611652605	1
29	Water Tank	20186565	1
30	Water Tank Cover	22246534	1
31	Heat-exchange Equipment	011004000013	1
32	Condenser Sub-Assy	01136263	1
33	Evaporator Sub-Assy	01036129P	1
34	Capillary Sub-Assy	030006000344	1
35	Adaptor sub-assy	26116155	1
36	Water Tray Sub-Assy	2018656402	1
37	Liquid Level Switch Sub-assy	0001940000901	1
38	Rubber Plug	76716054	1
39	Cover of drainage hole	22246097	1
40	Water Tray	20186563	1
41	Discharge Tube Sub-Assy	03001300280	1
42	Inhalation Tube Sub-Assy	03001000315	1
43	Covering Plate	01256043	1
44	Compressor and Fittings	00106545	1
45	Compressor Gasket	00901200013	3
46	Baffle Plate (Temperature & Humidity Sensor)	26116222	1
47	Cable Clamp	71010312	1
48	Chassis Sub-Assy	01206522	1
49	Castor	24236554	4
50	Electric Box Assy	100002064081	1
51	Electric Box Sub-Assy	01700700001	1
52	Insatallation Box	20116073	1
53	Capacitor CBB61S	3301074702	1
54	Capacitor CBB65	3300002241	1
55	main Board	300002060593	1
56	Electric Box Cover Sub-Assy	00001300016	1
57	Power Cord	4002028632	1

Above data is subject to change without notice.

10. Removal Procedure

Warning: disconnect power supply before removal; discharge the refrigerant completely before unsoldering the pipes.

PLATINUM EVO 21

Steps	Procedure
<p>1. Remove water tank assy</p> <p>Hold the handles at the two side of water tank and then remove the water tank assy.</p>	
<p>2. Remove panel</p> <p>Press the clasps at the two side of panel and pull the panel outwards and then lift it upwards to remove the panel.</p>	
<p>3. Remove filter sub-assy</p> <p>Hold the two raised handles of filter sub-assy outwards to separate the filter from the 5 clasps at the left and right side and the 5 grooves at the bottom; then remove the filter sub-assy.</p>	

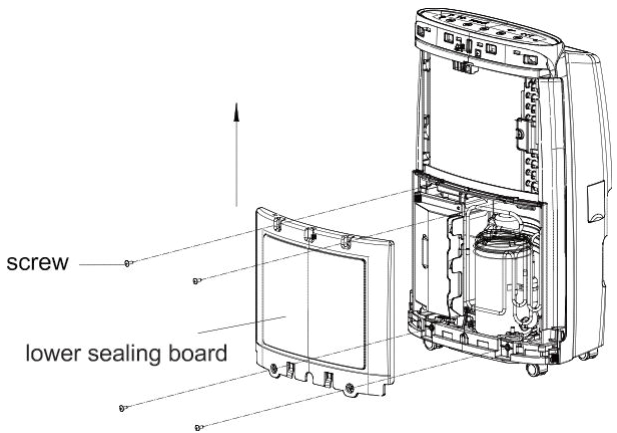
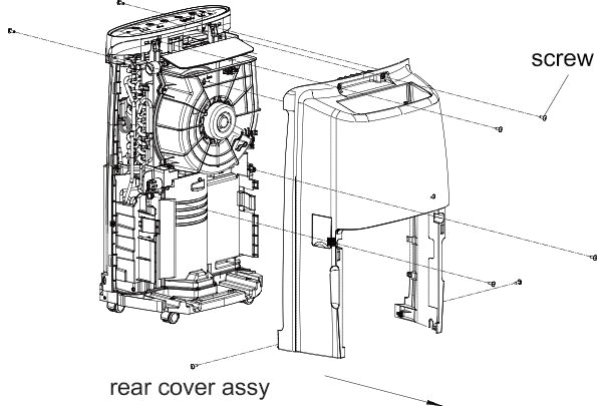
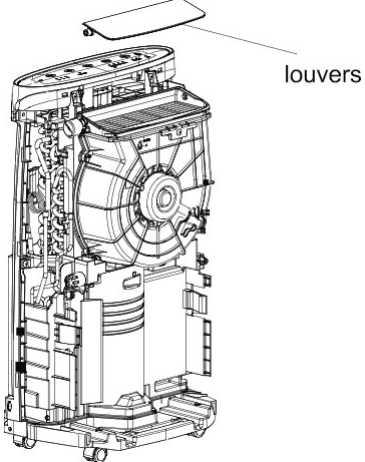
Steps	Procedure
4. Remove lower sealing board	<p>Remove the 4 screws of lower sealing board; lift it upwards to separate it from the 3 clasps at the top and then remove the lower sealing board.</p> 
5. Remove rear cover assy	<p>Remove the 2 screws at the front of case; remove the 4 screws at the back of case; remove the 4 screws at the left side and right side of case; hold the two sides of rear cover and then pull the rear cover outwards to remove it.</p> 
6. Remove louvers	<p>Remove the louvers from left to right.</p> 

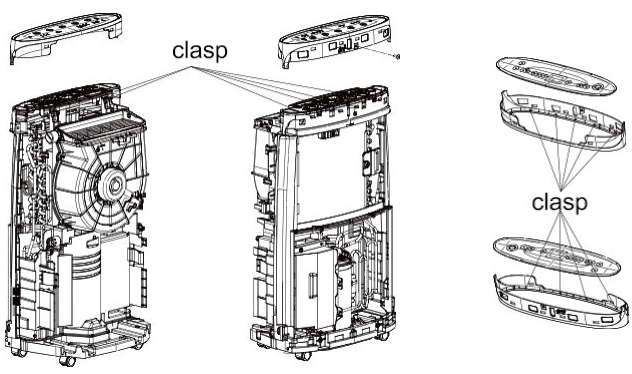
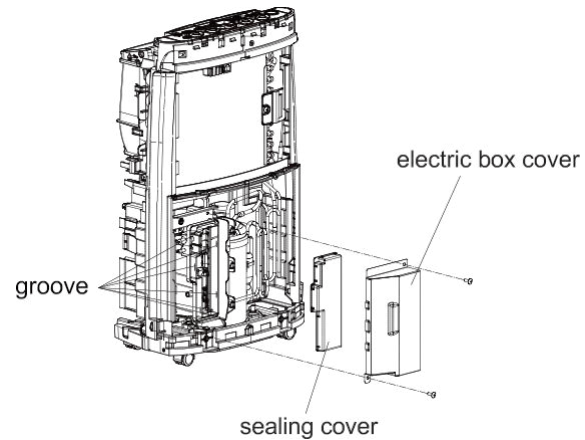
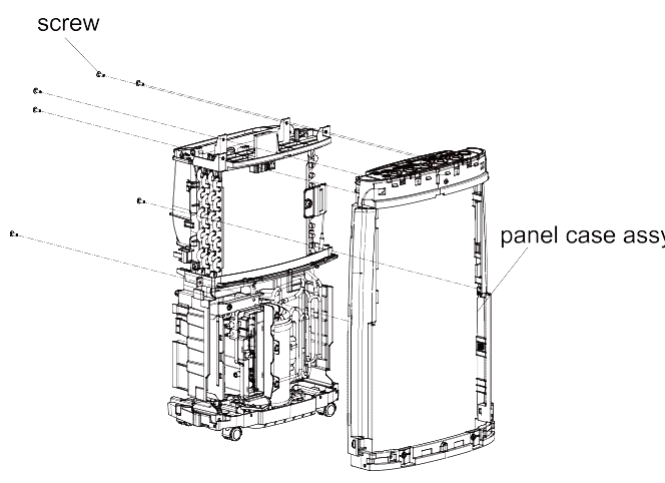
Steps	Procedure
<p>7. Remove panel case assy</p>	<p>Remove the 2 screws at the front of panel case; pull out the 6 clasps connecting with the support frame sub-assy and then remove the top plate and decoration ring. Separate the top plate from the 9 clasps on decoration ring. Separate the top plate and decoration ring.</p> 
<p>8. Remove electric box and sealing cover</p>	<p>Remove the 2 screws in the electric box cover and then remove the electric box cover; separate the sealing cover from the 6 grooves on the controller box and then remove the sealing cover.</p> 
<p>9. Remove support frame sub-assy</p>	<p>Remove the 6 screws at the back of panel case; separate the connection wire of discharge temperature sensor and connection wire with display board from all grooves; hold the two side of panel case; pull the panel case assy frontwards to remove it.</p> 

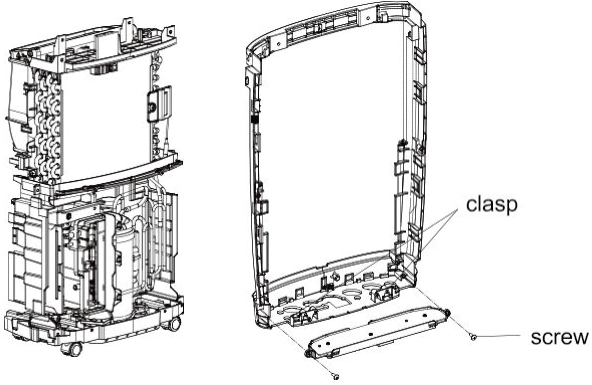
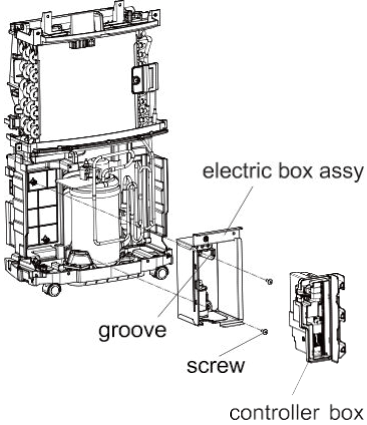
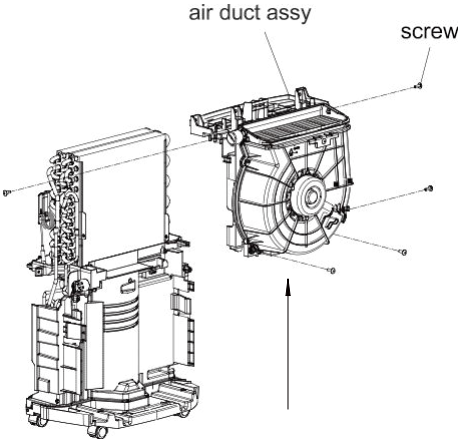
Steps	Procedure	
10. Remove display board	<p>Remove the 2 screws at the right and left side of display board; pull the clasps at the two sides to remove the display board.</p>	
11. Remove electric box assy	<p>Separate the controller box from the groove to remove the controller box; Remove the 2 screws in electric box, which are connected with water tray; disconnect all connection wires connecting each electronic component in the electric box; remove the electric box assy.</p>	
12. Remove air duct assy	<p>Remove the 2 screws fixing water tray and the 3 screws fixing evaporator and condenser; lift the air duct assy upwards to remove it.</p>	

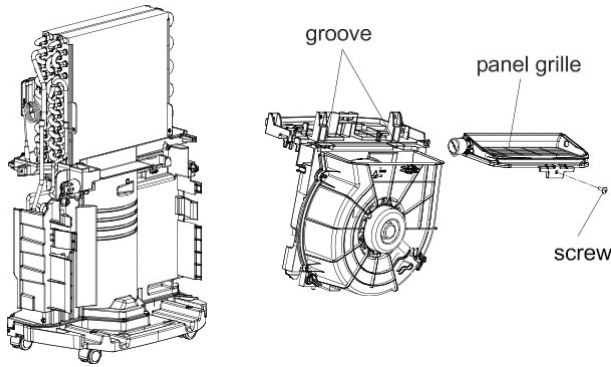
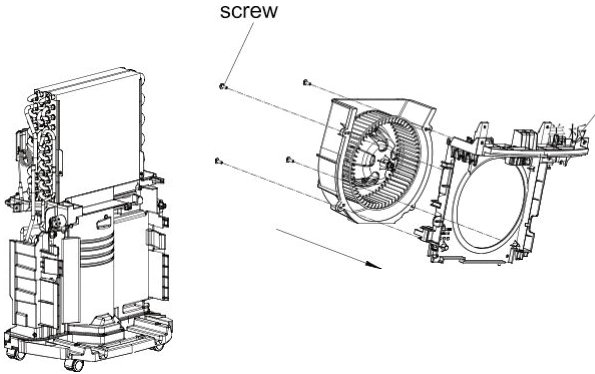
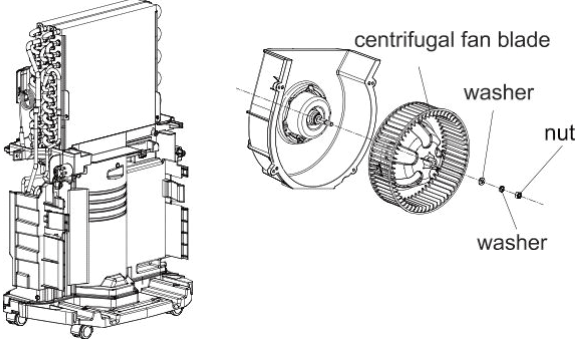
Steps	Procedure	
<p>13. Remove panel grille</p>	<p>Remove the one screw fixing the volute; pull the panel grille backwards to separate it from the two grooves and then remove the panel grille.</p>	
<p>14. Remove diversion ring</p>	<p>Remove the 4 screws fixing the back of cover plate on the volute and then remove the diversion ring.</p>	
<p>15. Remove centrifugal fan blade</p>	<p>Remove the nut fixing motor shaft and fan blade; remove the 2 washers; take out the fan blade along the motor shaft direction and then remove the fan blade sub-assy.</p>	

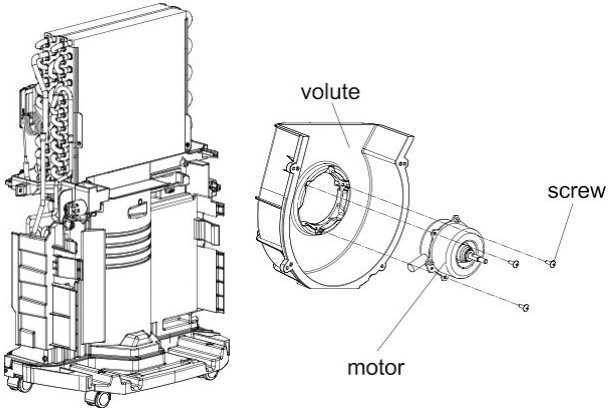
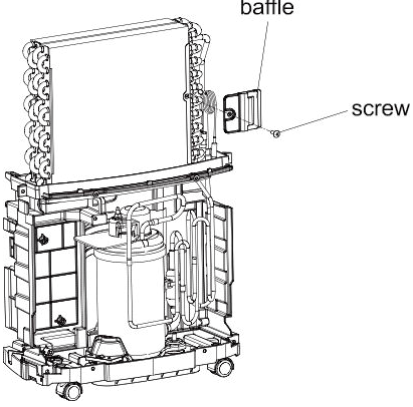
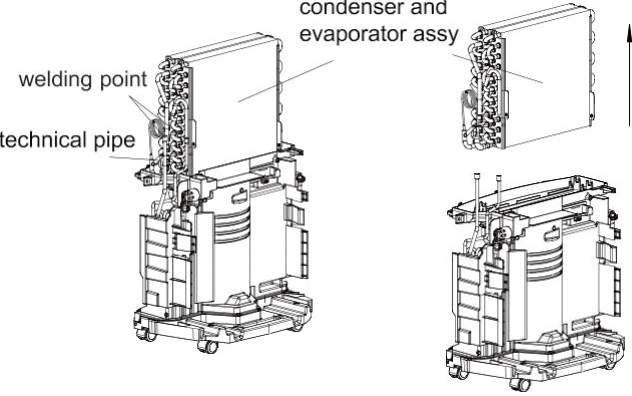
Steps	Procedure	
16. Remove motor		
17. Remove baffle		
18. Remove evaporator and condenser assy	<p data-bbox="300 1321 787 1496"> a Unsolder the points connecting suction pipe and discharge pipe with compressor and condenser and evaporator assy; remove the suction pipe and discharge pipe. Unsolder the points connecting capillary sub-assy with condenser assy and evaporator assy. Then remove the capillary sub-assy. Notices: 1. Make sure the refrigerant is discharged completely before unsolder the points. 2. When unsolder the welding point of capillary, please wrap the capillary completely with a wet cloth to avoid damage to the capillary caused by high temperature. Seal the ports of compressor discharge pipe and suction pipe with rubber plugs or tape, to avoid entering of foreign objects. </p> <p data-bbox="300 1736 787 1769"> b Lift the condenser and evaporator assy upwards to remove it. </p> 	

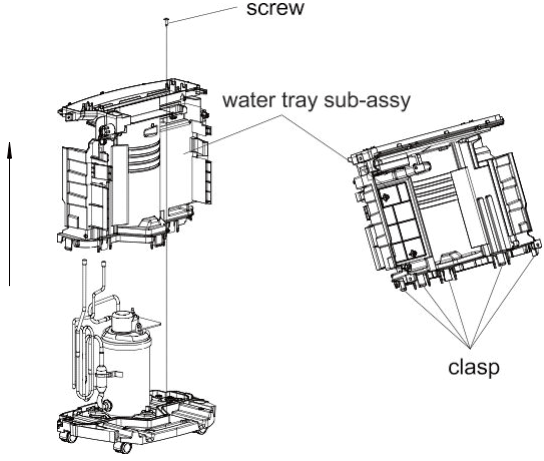
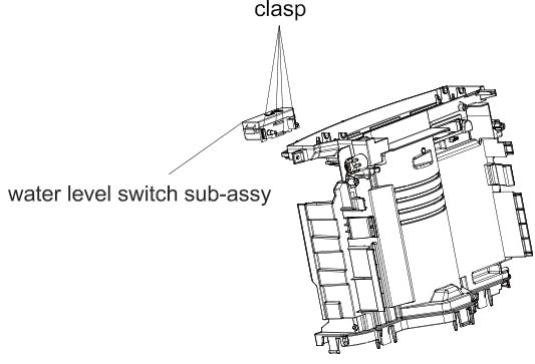
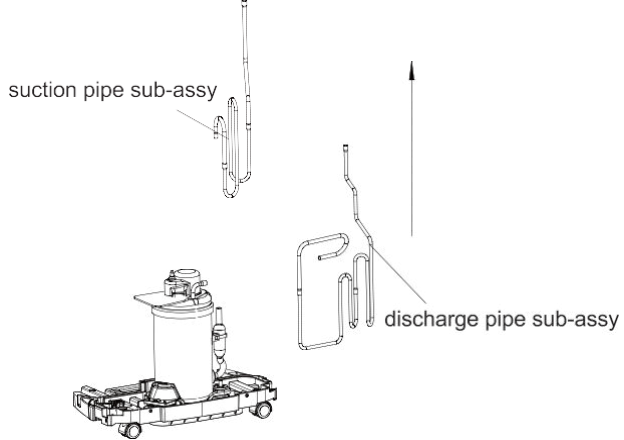
Steps	Procedure	Procedure
19. Remove water tray sub-assy	Remove the one screw connecting the water tray and chassis; loosen the 5 clasps connecting the water tray assy with the chassis and then remove the water tray assy.	 <p>The diagram illustrates the removal of the water tray sub-assembly. It shows a top view of the water tray sub-assembly with a screw and five clasps. A side view shows the water tray sub-assembly being lifted away from the chassis, with an upward arrow indicating the direction of removal. Labels include 'screw', 'water tray sub-assy', and 'clasp'.</p>
20. Remove water level switch sub-assy	Remove the 4 clasps connecting the water level switch sub-assy with the water tray and then remove the water level switch sub-assy.	 <p>The diagram illustrates the removal of the water level switch sub-assembly. It shows a side view of the water level switch sub-assembly being lifted away from the water tray, with an upward arrow indicating the direction of removal. A label 'clasp' points to the connection point between the sub-assembly and the water tray. Another label 'water level switch sub-assy' points to the sub-assembly itself.</p>
21. Remove suction pipe sub-assy and discharge pipe sub-assy	Unsolder the suction pipe and discharge pipe from the welding point of suction port and discharge port of compressor; remove the suction pipe sub-assy and discharge pipe sub-assy.	 <p>The diagram illustrates the removal of the suction and discharge pipe sub-assemblies. It shows a side view of the suction pipe sub-assembly and the discharge pipe sub-assembly being lifted away from the compressor, with an upward arrow indicating the direction of removal. Labels include 'suction pipe sub-assy' and 'discharge pipe sub-assy'.</p>

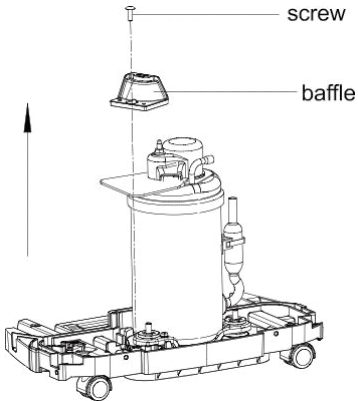
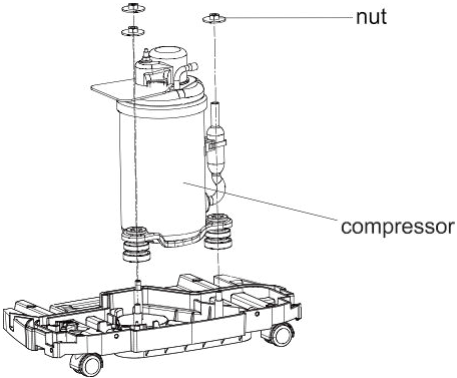
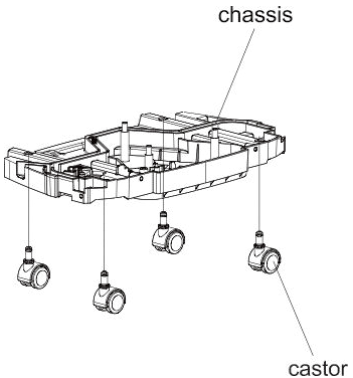
Steps	Procedure	
22. Remove baffle	<p>Remove the one screw in the baffle and then remove the baffle.</p>	
23. Remove compressor and its accessories	<p>Remove the 3 nuts fixing compressor and then lift the compressor upwards to remove it.</p>	
24. Remove castors	<p>Pull out the castors forcibly and then remove the 4 castors.</p>	

GDN40AU-K5EBA1A

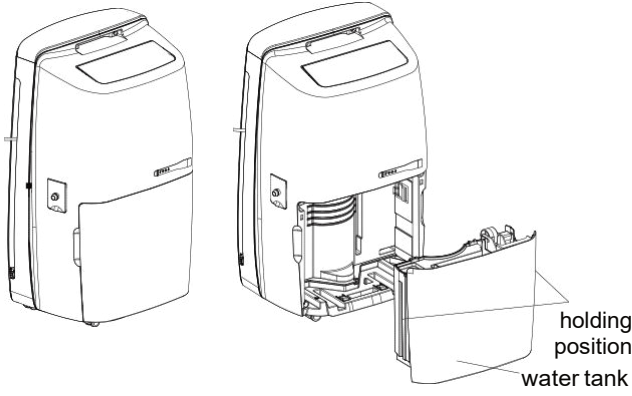
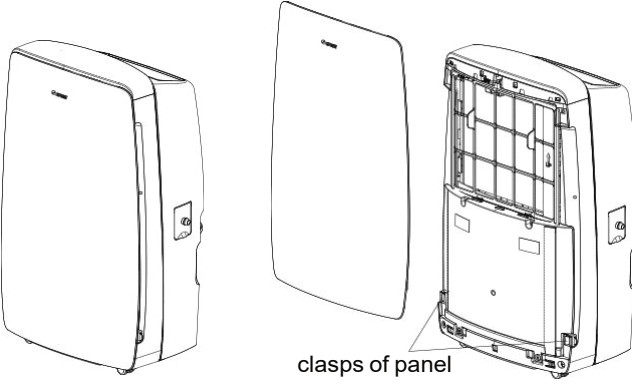
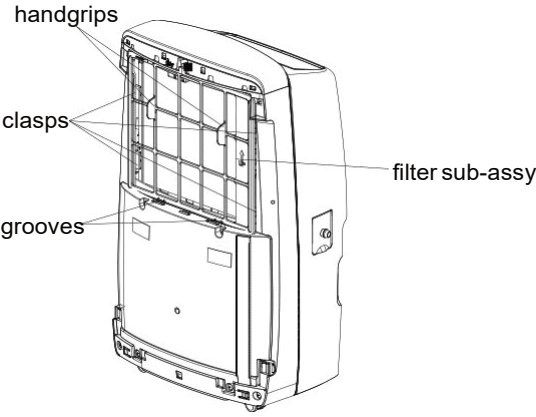
Step		Procedure
1. Remove water tank	<p>Hold the holding position at both sides of water tank with both hands to pull it outwards and then remove the water tank.</p>	
2. Remove panel	<p>Press the clasps at both sides of panel with both hands to pull it outwards, lift it upwards and then remove the panel.</p>	
3. Remove filter sub-assy	<p>Hold two handgrips on filter sub-assy to pull it outwards to let it separate from 4 clasps at both side and 2 grooves at the bottom, and then remove the filter sub-assy.</p>	

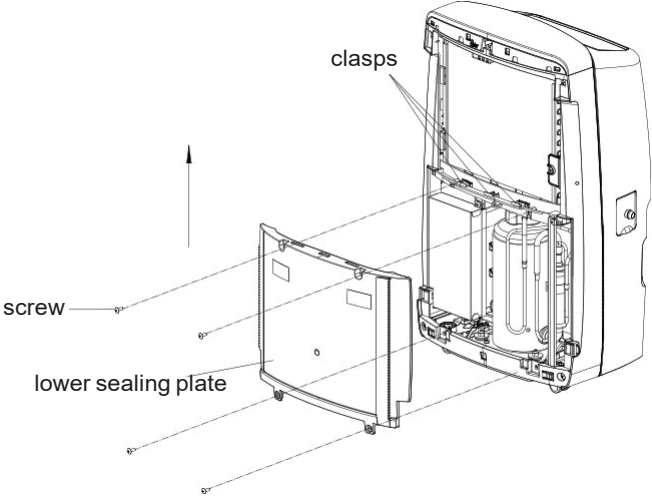
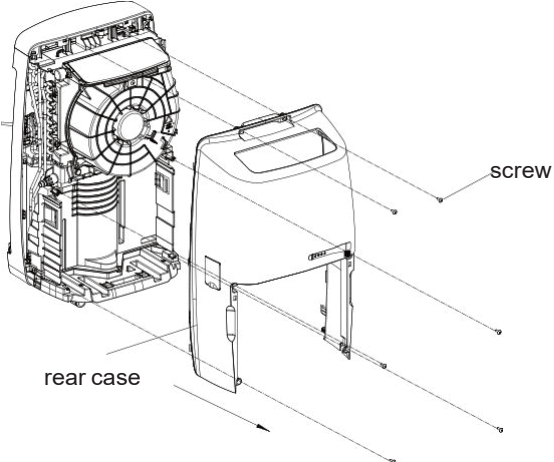
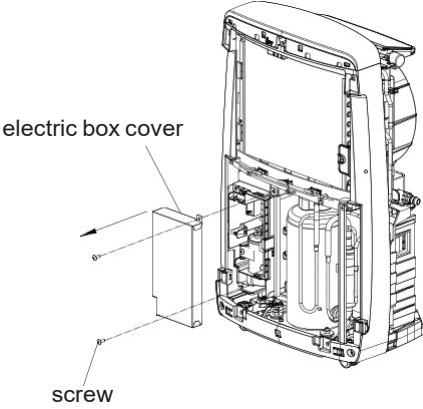
Step	Procedure
<p data-bbox="71 198 391 224">4. Remove lower sealing plate</p> <p data-bbox="215 303 691 412">Remove 4 screws on lower sealing plate, lift it upwards to let it separate from upper 3 clasps, and then remove the lower sealing plate.</p>	
<p data-bbox="58 773 289 799">5. Remove rear cover</p> <p data-bbox="215 867 691 947">Remove 6 screws at the back of the case, hold both sides of rear cover, pull it outwards and then remove the rear cover.</p>	
<p data-bbox="82 1290 488 1316">6. Remove electric box cover sub-assy</p> <p data-bbox="215 1386 667 1443">Remove 2 screws on electric box cover, and then remove the electric box cover.</p>	

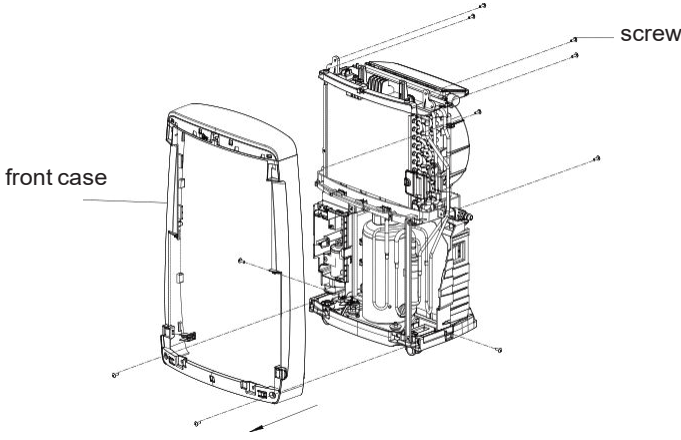
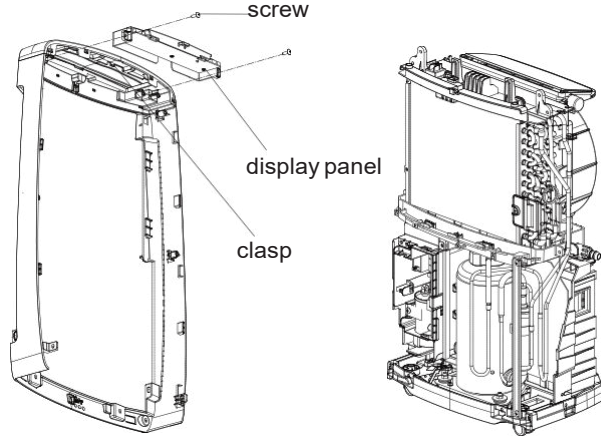
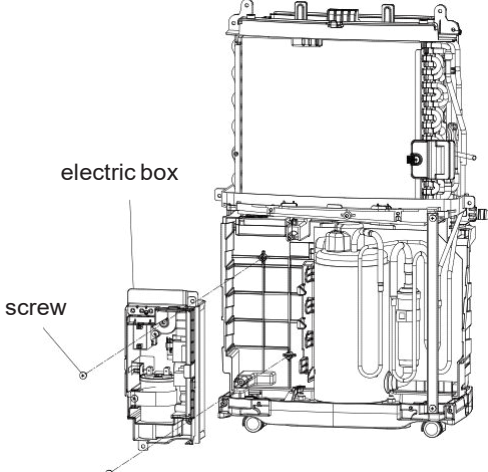
Step		Procedure
7. Remove front case	<p>Remove 2 screws at the front of the front case, 2 screws at both sides and 6 screws at the back side to let connection wires of discharge temperature sensor and display board separate from all grooves. Hold both sides of front case to pull it outwards and then remove the front case.</p>	
8. Remove display board	<p>Remove 2 screws at both side of display board, pull out the middle clasps and then remove the display board.</p>	
9. Remove electric box	<p>Remove 2 screws inside the electric box used for connecting water tray, pull out all wires connecting electric parts inside the electric box, and then remove the electric box.</p>	

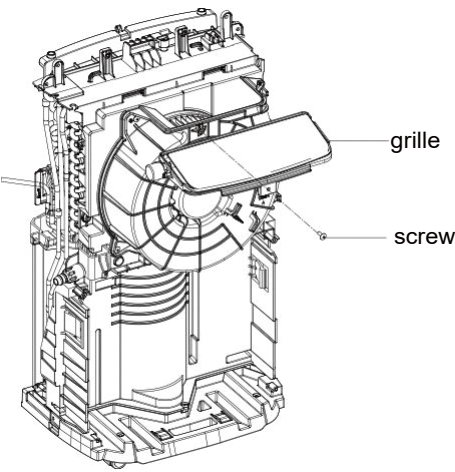
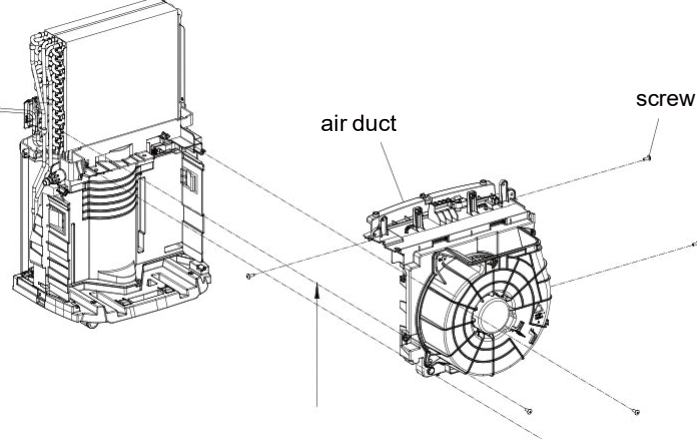
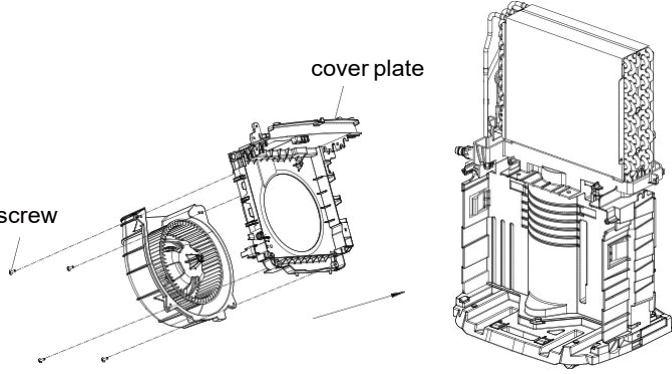
Step	Procedure	Procedure
10.Remove grille	<p>Remove 1 screw fixing grille, hold both Side of grille and then pull it outwards to Remove it.</p>	 <p>grille</p> <p>screw</p>
11.Remove air duct	<p>Remove 3 screws fixing the water tray and 3 screws fixing condenser and evaporator, lift up the air duct and then remove it .</p>	 <p>air duct</p> <p>screw</p>
12.Remove cover plate	<p>Remove 4 screws fixed on the propeller housing at the back of the cover plate and then remove the cover plate.</p>	 <p>cover plate</p> <p>screw</p>

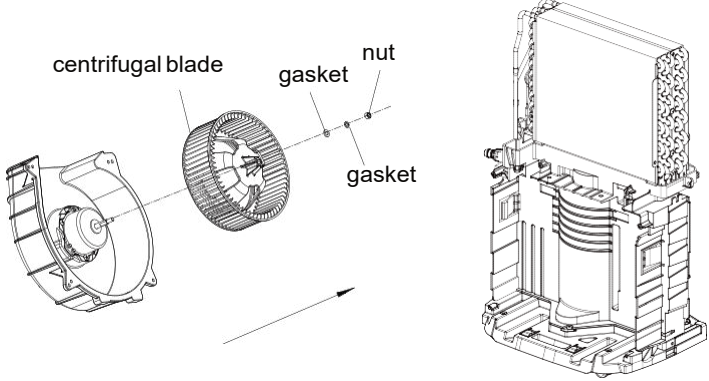
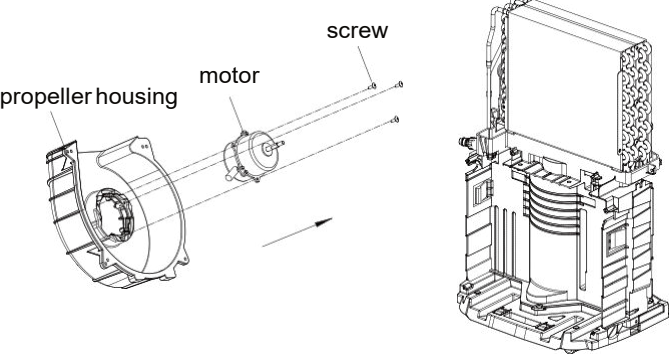
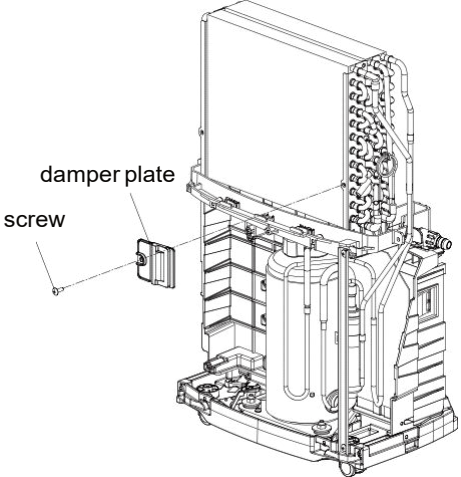
Step	Procedure
<p>13.Remove centrifugal blade</p>	<p>Remove nut and 2 gasket fixing the blade at the motor shaft terminal, take out the blade along the motor shaft and then remove the blade sub-assy.</p> 
<p>14.Remove motor</p>	<p>Remove 3 screws fixing the motor and then remove the motor.</p> 
<p>15.Remove damper plate</p>	<p>Remove 1 screw fixing the damper plate and then remove the damper plate.</p> 

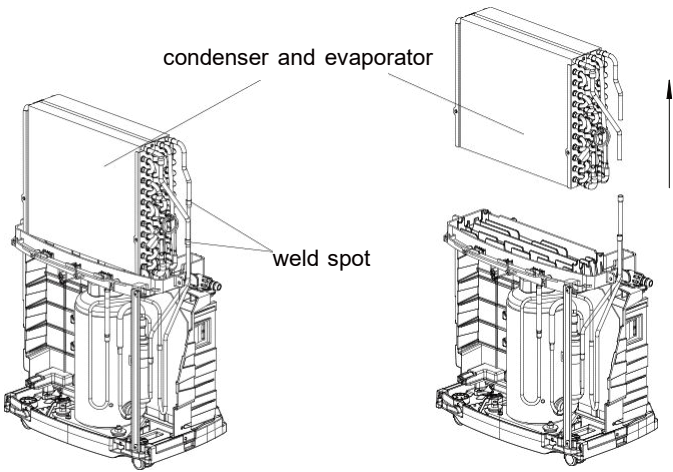
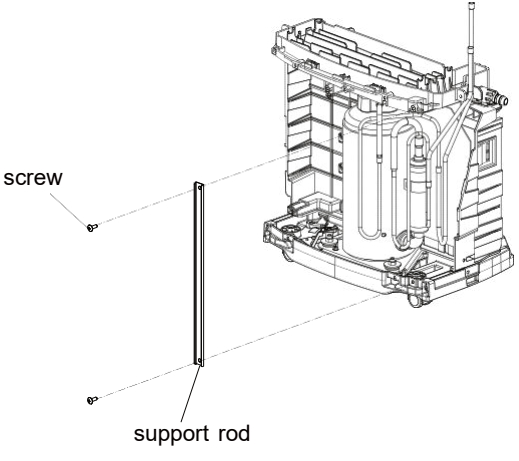
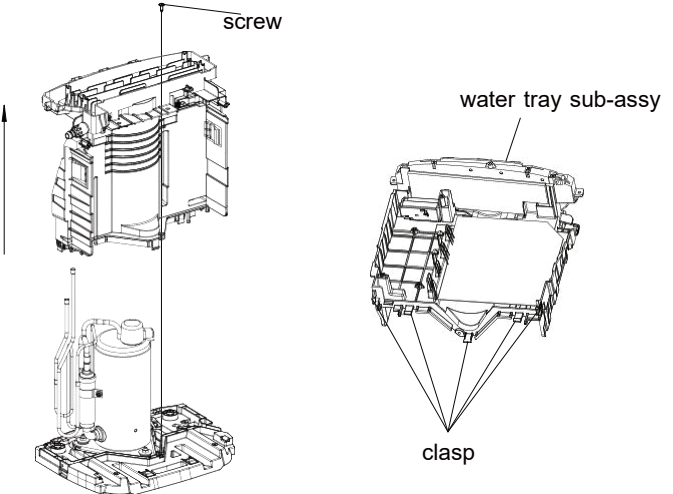
Step	Procedure
16. Remove condenser and evaporator	 <p>condenser and evaporator</p> <p>weld spot</p>
<p>a</p> <p>Unsolder the spot weld between suction pipe, discharge pipe and evaporator, condenser, and remove suction pipe and discharge pipe. Unsolder the spot weld between capillary sub-assy and condenser, evaporator, and then remove capillary sub-assy.</p> <p>Note:</p> <ol style="list-style-type: none"> 1. Before unsoldering the spot weld, please confirm the refrigerant is discharged completely. 2. When unsoldering the spot weld of capillary, wrap the capillary with wet cloth to prevent damage to capillary due to high temperature. 	<p>b</p> <p>Lift it upwards and then remove the evaporator and the condenser.</p>
17.Remove support rod	 <p>screw</p> <p>support rod</p>
18.Remove water tray sub-assy	 <p>screw</p> <p>water tray sub-assy</p> <p>clasp</p>
<p>Remove one screw connecting water tray and chassis, loose 5 clasps connecting the chassis and then remove the water tray.</p>	

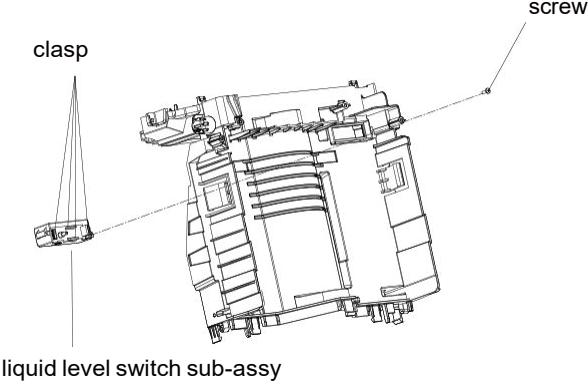
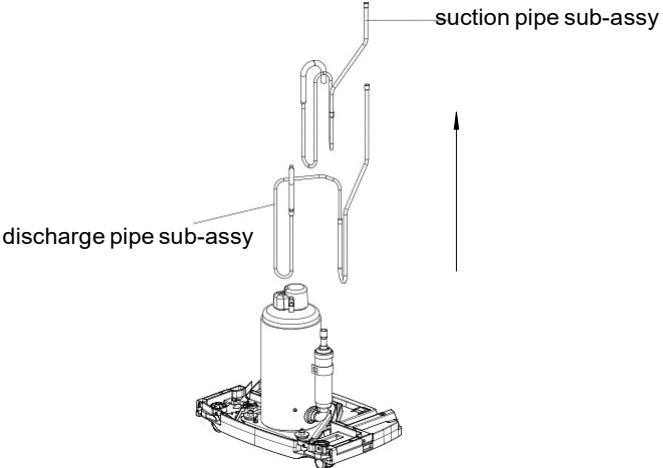
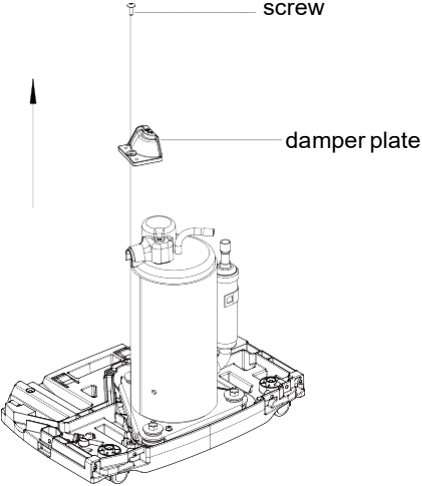
Step	Procedure
<p data-bbox="99 209 516 235">19. Remove liquid level switch sub-assy</p> <p data-bbox="251 314 709 423">Remove one screw fixing the liquid level switch. Loose 4 clasos connecting the water tray, and then remove the liquid level switch sub-assy.</p>	
<p data-bbox="99 781 724 808">20. Remove suction pipe sub-assy, discharge pipe sub-assy</p> <p data-bbox="232 880 735 1013">Unsolder suction pipe and discharge pipe from the welding position of suction outlet and discharge outlet of compressor, and the remove suction pipe sub-assy and discharge pipe sub-assy.</p>	
<p data-bbox="121 1295 393 1321">21. Remove damper plate</p> <p data-bbox="251 1393 701 1450">Remove one screw on the damper plate and then remove the damper plate.</p>	

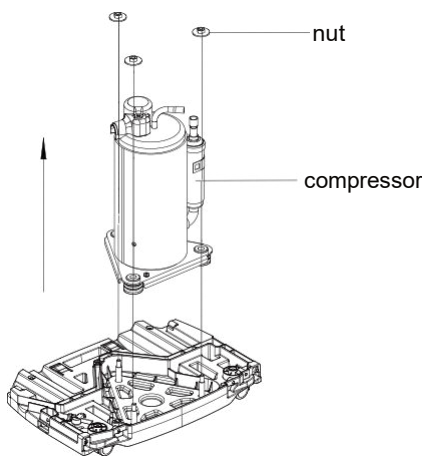
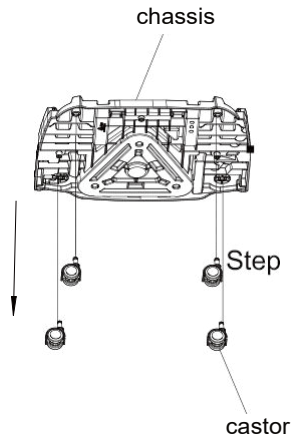
Step	Procedure	
<p>22.Remove compressor and its fittings</p> <p>Remove 2 nuts fixing the compressor, lift up the compressor and then remove the compressor.</p>		
<p>23.Remove castor</p> <p>Pull out 4 castors to remove them.</p>		

PLATINUM EVO 41

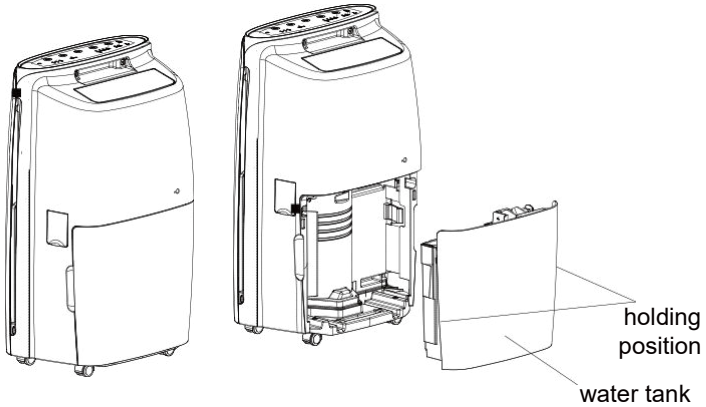
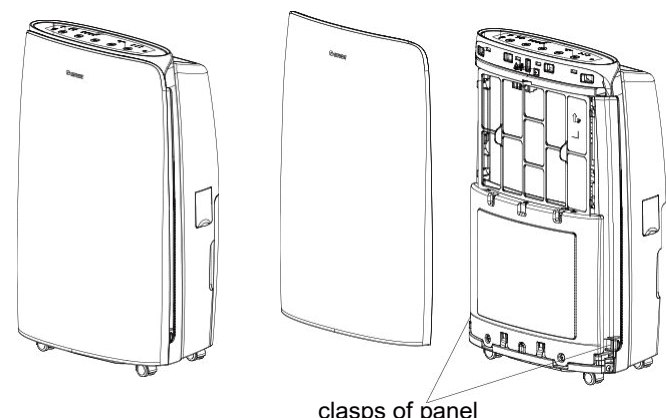
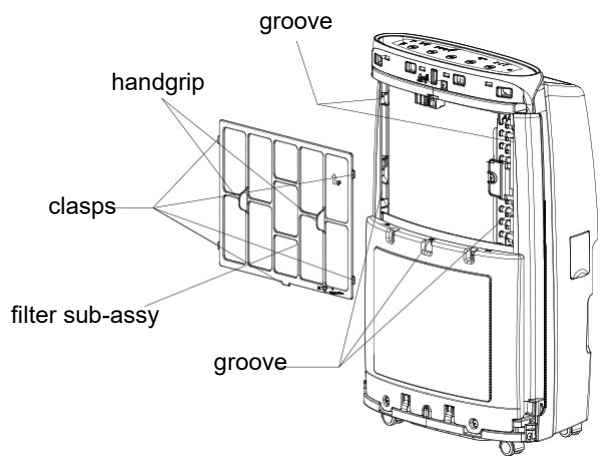
Step	Procedure	Procedure
1. Remove water tank	<p>Hold the holding position at both sides of water tank with both hands to pull it outwards and then remove the water tank.</p>	
2. Remove panel	<p>Press the clasps at both sides of panel with both hands to pull it outwards, lift it upwards and then remove the panel.</p> <p>Procedur e</p>	
3. Remove filter sub-assy	<p>Hold two handgrips on filter sub-assy to pull it outwards to let it separate from 5 clasps at both side and 5 grooves at the bottom, and then remove the filter sub-assy.</p>	

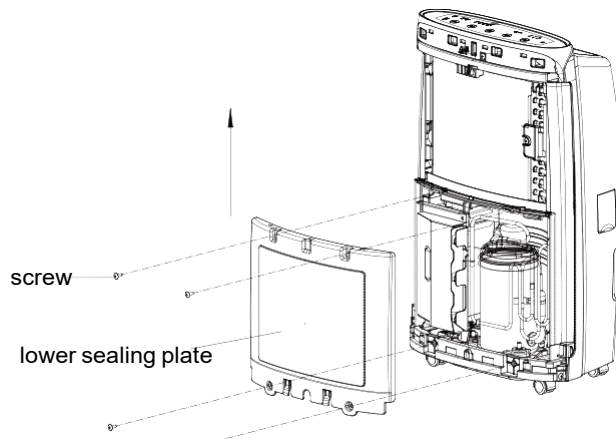
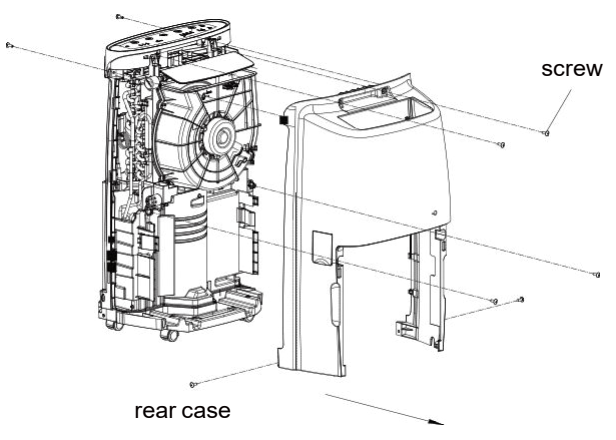
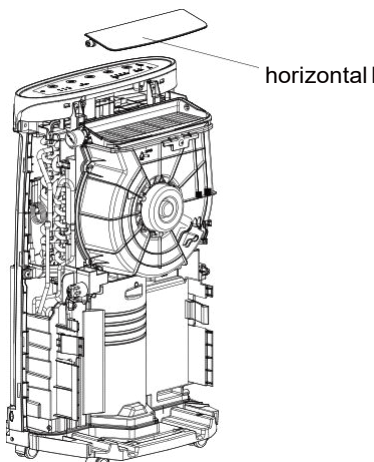
Step	Procedure	
<p>4.Remove lower sealing plate</p>	<p>Remove 4 screws on lower sealing plate, lift it upwards to let it separate from upper 3 clasps, and then remove the lower sealing plate.</p>	
<p>5.Remove rear cover</p>	<p>Remove 2 screws at the front side of case, 4 screws at the back side and 4 screws at both sides, hold both sides of rear cover, pull it outwards and then remove the rear cover.</p>	
<p>6. Remove horizontal louver</p>	<p>Remove the horizontal louver from left to right direction. .</p>	

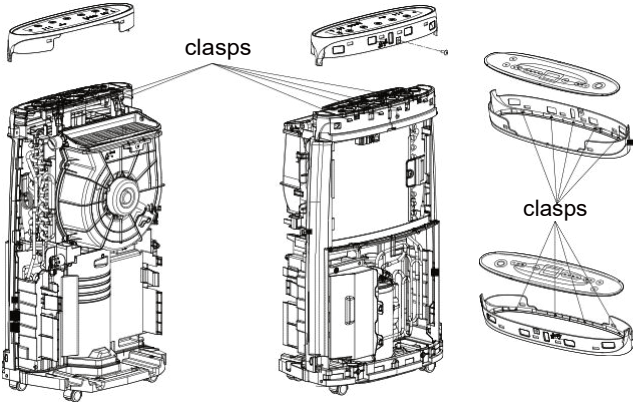
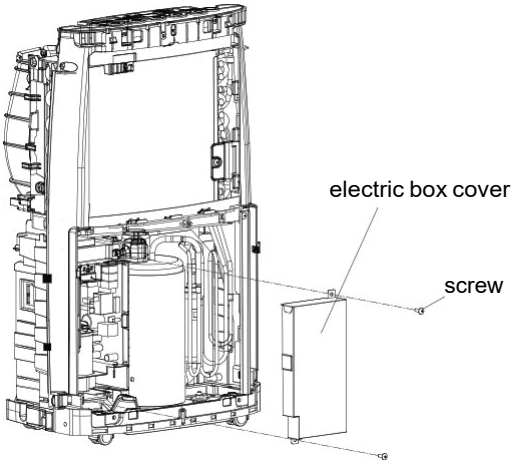
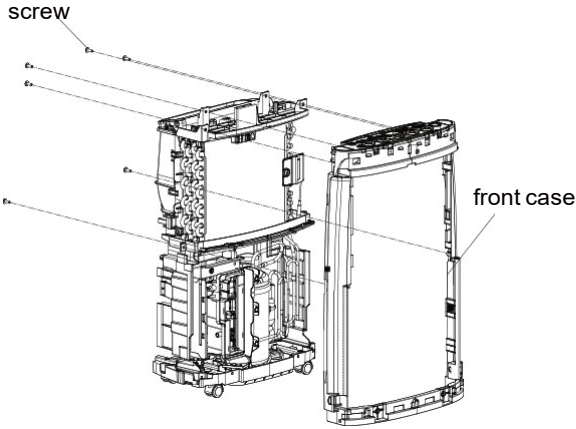
Step		Procedure
7.Remove front case	<p>Remove 2 screws at the front of the front case,pull out 6 screws connecting with support rack sub-assy, and remove top plate and decorative ring. Let the top plate separate from 9 clasps on decorative ring,and then separate the top plate from the decorative ring.</p>	
8.Remove electric box cover	<p>Remove 2 screws fixing the electric box cover,and then remove electric box cover.</p>	
9. Remove support rack sub-assy	<p>Remove 6 screws at the back of front case, make connection wires discharge temperature sensor and display board separate from all groves. Hold both sides of front case to pull it to the front and then remove the front case.</p>	

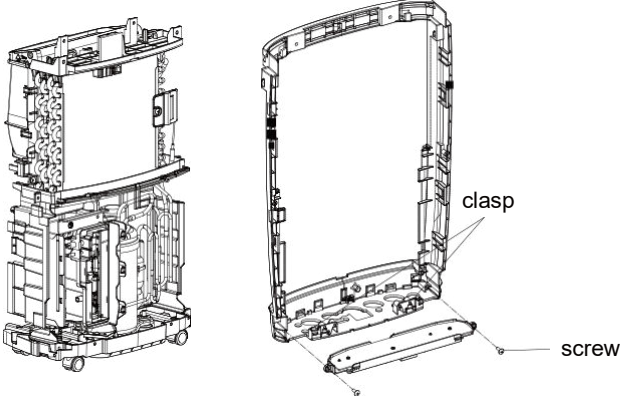
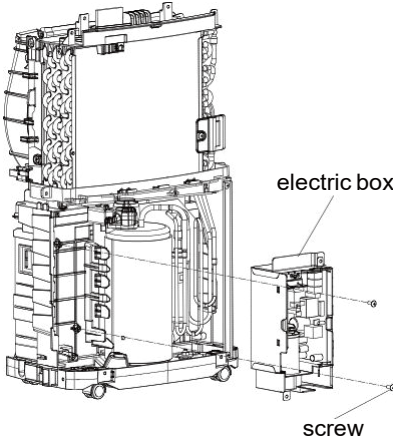
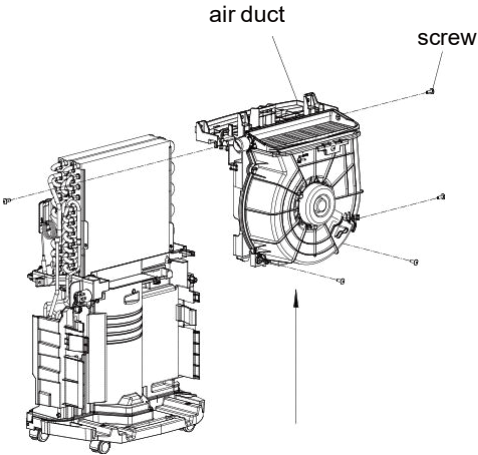
Step	Procedure
<p>10.Remove display board</p> <p>Remove 2 screws at both sides of display board, pull out clasps at both sides and then remove the display board.</p>	
<p>11.Remove electric box</p> <p>Remove 2 screws inside the electric box connecting the water tray, pull out all wires connecting all electric parts inside the electric box, and then remove the electric box.</p>	
<p>12.Remove air duct</p> <p>Remove 2 screws fixing the water tray and 3 screws fixing condenser and evaporator, lift up the air duct and then remove it.</p>	

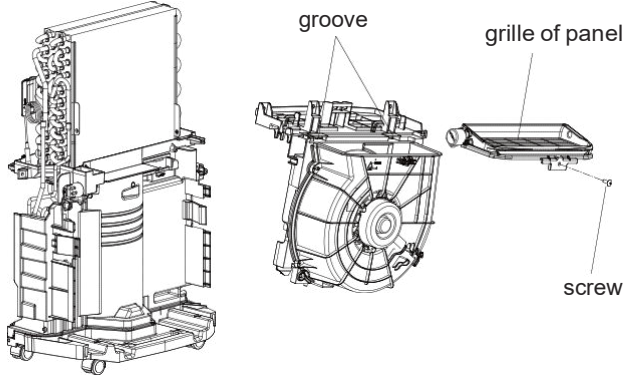
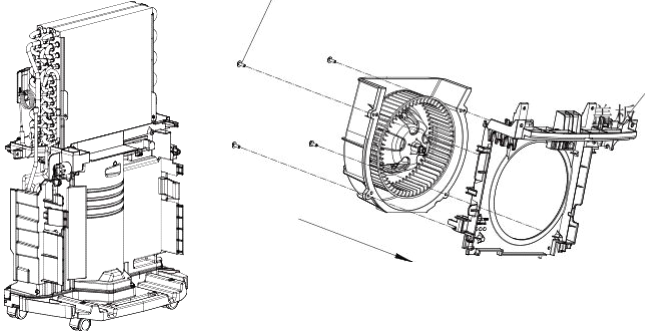
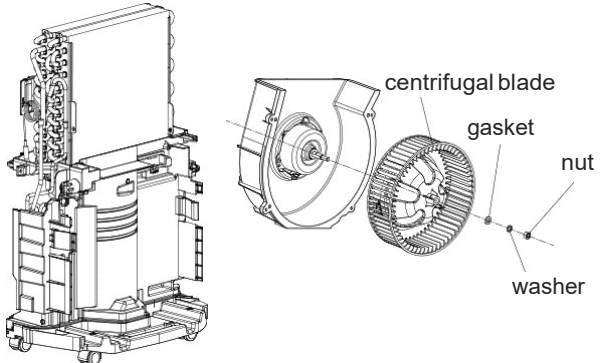
Step	Procedure
13.Remove grille	
	<p>Remove one screw fixing the propeller housing, pull the grille backwards to let it separate from 2 grooves, and then remove the grille.</p>
	
14.Remove guide loop	
	<p>Remove 4 screws fixing the propeller housing at the back of cover plate, and then remove the guide loop.</p>
	
15.Remove centrifugal blade	
	<p>Remove nut and 2 gaskets fixing the Blade at the motor shaft terminal, take out the blade along the motor shaft and then remove the blade sub-assy.</p>
	

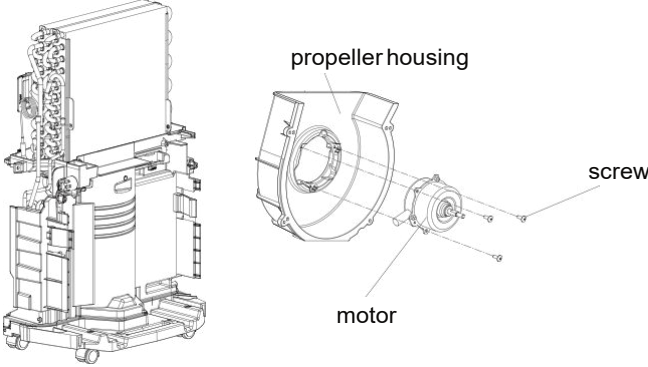
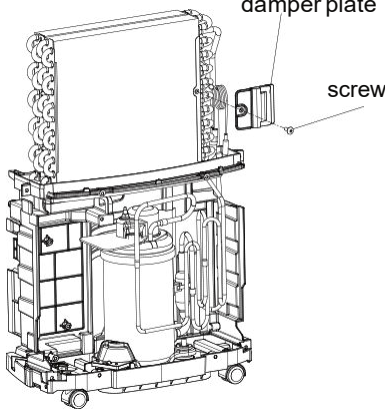
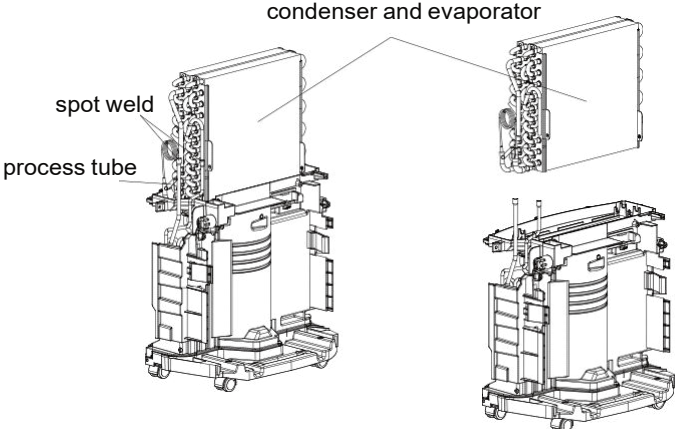
Step	Procedure	
16.Remove motor		
	<p>Remove 3 screws fixing the motor and then remove the motor.</p>	
17.Remove damper plate		
	<p>Remove 1 screw fixing the damper plate and then remove the damper plate.</p>	
18.Remove condenser and evaporator		
<p>a</p> <p>Unsolder the spot weld between suction pipe, discharge pipe and evaporator, condenser,and remove suction pipe and discharge pipe.Unsolder the spot weld between capillary sub-assy and condenser, evaporator, and then remove capillary sub-assy.</p> <p>Note: 1. Before unsoldering the spot weld, please Confirm the refrigerant is discharged completely. 2. When unsoldering the spot weld of capillary,wrap the capillary with wet cloth to prevent damage to capillary due to high temperature. Seal the discharge pipe outlet and suction pipe outlet with rubber cork or gummed paper to prevent sundries getting into it.</p>	<p>b</p> <p>Lift it upwards and then remove the evaporator and the condenser.</p>	

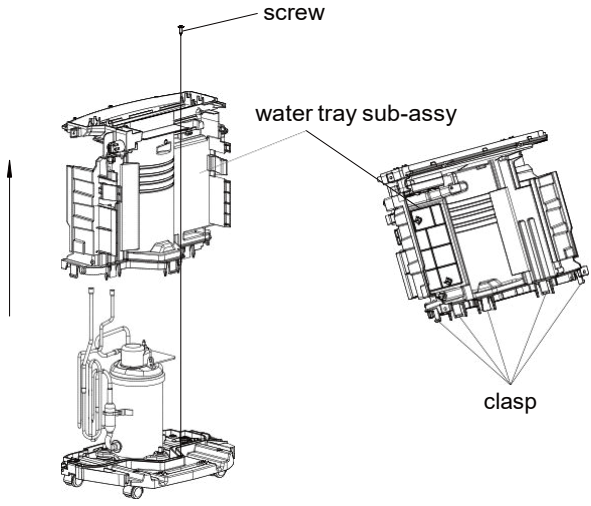
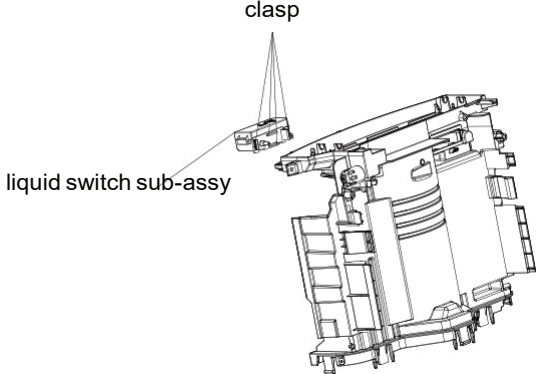
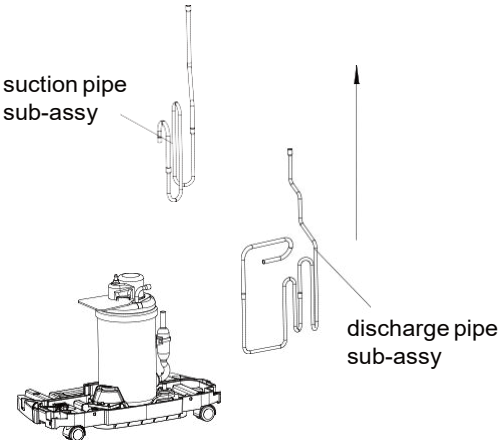
Step	Procedure	Image
19.Remove water tray sub-assy		
Remove one screw connecting water tray and chassis, loose 5 clasps connecting the chassis and then remove the water tray.		
20.Remove liquid level switch sub-assy		
Loose 4 clasps connecting the water tray, and then remove the liquid level switch sub-assy.		
21.Remove suction pipe sub-assy, discharge pipe sub-assy		
Unsolder suction pipe and discharge pipe from the welding position of suction outlet and discharge outlet of compressor, and the remove suction pipe sub-assy and discharge pipe sub-assy.		

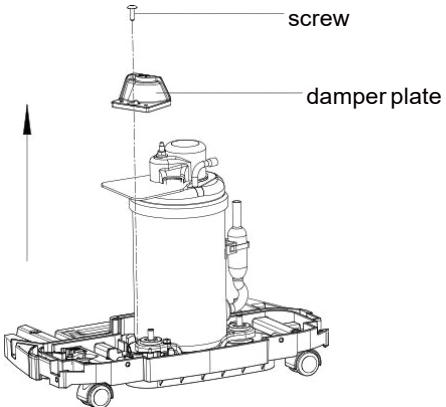
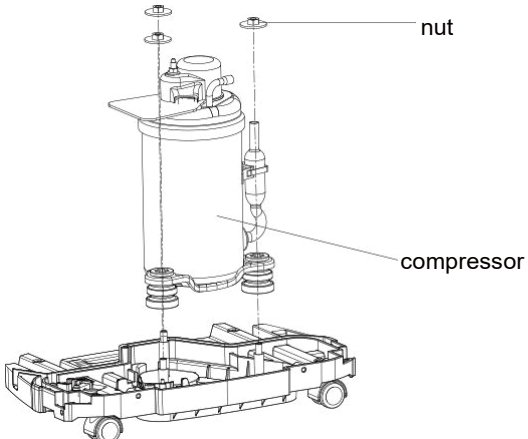
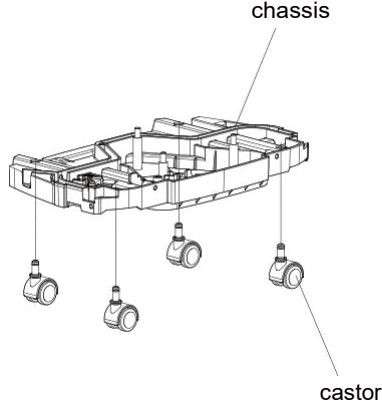
Step	Procedure
<p>22.Remove damper plate</p>	<p>Remove one screw on the damper plate and then remove the damper plate.</p>  <p>The diagram illustrates the removal of the damper plate. A screw is shown being removed from the top of the damper plate. An upward arrow indicates the direction of removal.</p>
<p>23.Remove compressor and its fittings</p>	<p>Remove 3 nuts fixing the compressor, lift up the compressor and then remove the compressor.</p>  <p>The diagram illustrates the removal of the compressor. Three nuts are shown being removed from the base of the compressor unit.</p>
<p>24.Remove castor</p>	<p>Pull out 4 castors to remove them.</p>  <p>The diagram illustrates the removal of the castors. The chassis is shown with four castors being pulled out.</p>

Appendix:

Appendix 1: Reference Sheet of Celsius and Fahrenheit

Conversion formula for Fahrenheit degree and Celsius degree: $T_f = T_c \times 1.8 + 32$

Set temperature

Fahrenheit display temperature (°F)	Fahrenheit (°F)	Celsius (°C)	Fahrenheit display temperature (°F)	Fahrenheit (°F)	Celsius (°C)	Fahrenheit display temperature (°F)	Fahrenheit (°F)	Celsius (°C)
61	60.8	16	69/70	69.8	21	78/79	78.8	26
62/63	62.6	17	71/72	71.6	22	80/81	80.6	27
64/65	64.4	18	73/74	73.4	23	82/83	82.4	28
66/67	66.2	19	75/76	75.2	24	84/85	84.2	29
68	68	20	77	77	25	86	86	30

Ambient temperature

Fahrenheit display temperature (°F)	Fahrenheit (°F)	Celsius (°C)	Fahrenheit display temperature (°F)	Fahrenheit (°F)	Celsius (°C)	Fahrenheit display temperature (°F)	Fahrenheit (°F)	Celsius (°C)
32/33	32	0	55/56	55.4	13	79/80	78.8	26
34/35	33.8	1	57/58	57.2	14	81	80.6	27
36	35.6	2	59/60	59	15	82/83	82.4	28
37/38	37.4	3	61/62	60.8	16	84/85	84.2	29
39/40	39.2	4	63	62.6	17	86/87	86	30
41/42	41	5	64/65	64.4	18	88/89	87.8	31
43/44	42.8	6	66/67	66.2	19	90	89.6	32
45	44.6	7	68/69	68	20	91/92	91.4	33
46/47	46.4	8	70/71	69.8	21	93/94	93.2	34
48/49	48.2	9	72	71.6	22	95/96	95	35
50/51	50	10	73/74	73.4	23	97/98	96.8	36
52/53	51.8	11	75/76	75.2	24	99	98.6	37
54	53.6	12	77/78	77	25			

Appendix 2: Resistance Table of Tube Temperature Sensor

Resistance table of Tube Temperature Sensor (20K)

Temp(°C)	Resistance(kΩ)	Temp(°C)	Resistance(kΩ)	Temp(°C)	Resistance(kΩ)	Temp(°C)	Resistance(kΩ)
-19	181.4	20	25.01	59	5.13	98	1.427
-18	171.4	21	23.9	60	4.948	99	1.386
-17	162.1	22	22.85	61	4.773	100	1.346
-16	153.3	23	21.85	62	4.605	101	1.307
-15	145	24	20.9	63	4.443	102	1.269
-14	137.2	25	20	64	4.289	103	1.233
-13	129.9	26	19.14	65	4.14	104	1.198
-12	123	27	18.13	66	3.998	105	1.164
-11	116.5	28	17.55	67	3.861	106	1.131
-10	110.3	29	16.8	68	3.729	107	1.099
-9	104.6	30	16.1	69	3.603	108	1.069
-8	99.13	31	15.43	70	3.481	109	1.039
-7	94	32	14.79	71	3.364	110	1.01
-6	89.17	33	14.18	72	3.252	111	0.983
-5	84.61	34	13.59	73	3.144	112	0.956
-4	80.31	35	13.04	74	3.04	113	0.93
-3	76.24	36	12.51	75	2.94	114	0.904
-2	72.41	37	12	76	2.844	115	0.88
-1	68.79	38	11.52	77	2.752	116	0.856
0	65.37	39	11.06	78	2.663	117	0.833
1	62.13	40	10.62	79	2.577	118	0.811
2	59.08	41	10.2	80	2.495	119	0.77
3	56.19	42	9.803	81	2.415	120	0.769
4	53.46	43	9.42	82	2.339	121	0.746
5	50.87	44	9.054	83	2.265	122	0.729
6	48.42	45	8.705	84	2.194	123	0.71
7	46.11	46	8.37	85	2.125	124	0.692
8	43.92	47	8.051	86	2.059	125	0.674
9	41.84	48	7.745	87	1.996	126	0.658
10	39.87	49	7.453	88	1.934	127	0.64
11	38.01	50	7.173	89	1.875	128	0.623
12	36.24	51	6.905	90	1.818	129	0.607
13	34.57	52	6.648	91	1.736	130	0.592
14	32.98	53	6.403	92	1.71	131	0.577
15	31.47	54	6.167	93	1.658	132	0.563
16	30.04	55	5.942	94	1.609	133	0.549
17	28.68	56	5.726	95	1.561	134	0.535
18	27.39	57	5.519	96	1.515	135	0.521
19	26.17	58	5.32	97	1.47	136	0.509

REGULATION (EU) No. 517/2014 – F-GAS

PLATINUM EVO 21

The unit contains R290, a natural greenhouse gas with global warming potential (GWP) = 3 - Kg. 0.06 = 0.00018
Tons CO₂ equiv.

PLATINUM EVO 41

The unit contains R290, a natural greenhouse gas with global warming potential (GWP) = 3 - Kg. 0.15 = 0.00045
Tons CO₂ equiv.

Do not release R290 into the atmosphere.



www.argoclima.com